



nismo

INSTALLATION INSTRUCTIONS

- DESCRIPTION: Side Sill Protector**
- APPLICATION: Z**
- PART NUMBER: G68E0 1EAxx (xx Designates color)**
- KIT CONTENTS:**

Item	Qty.	Description	Part Number
A	1	Side Sill - RH	-
B	1	Side Sill - LH	-
C	6	Grommet	-
D	1	Installation Instructions	-

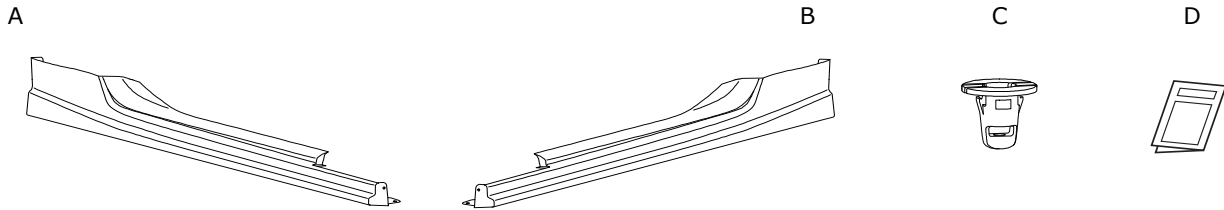

- TOOLS REQUIRED:**
 - 50/50 alcohol/water solution
 - Socket wrench 10 mm (25/64")
 - Clean, lint-free wiping cloth
 - Clip remover
 - Stubby driver
 - Masking tape

6. PRE-INSTALLATION CAUTIONS/NOTES:

CAUTION

- Install the Side Sill Protector when the ambient temperature is above 60°F (15°C).
- Do not wash or expose the vehicle to a wet environment for 24 hours after installing the Side Sill Protector.

NOTE

- These instructions are for the left side of the vehicle; the same procedure applies to the right side.

INSTALLATION INSTRUCTIONS - Side Sill Protector

7. INSTALLATION PROCEDURE:

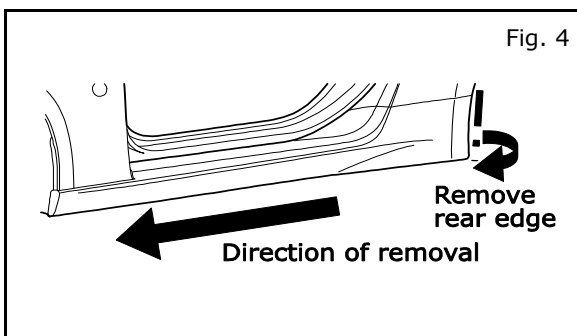
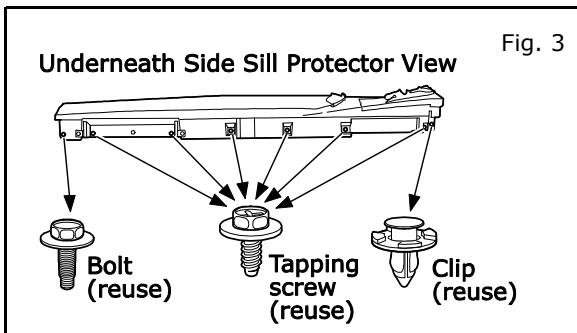
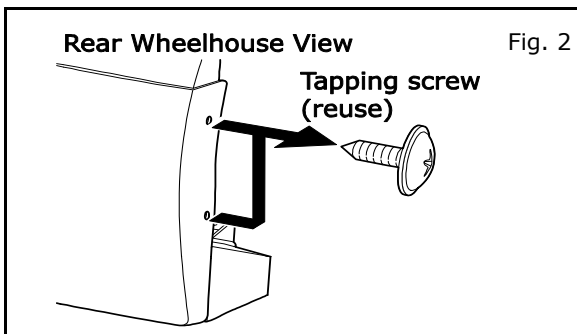
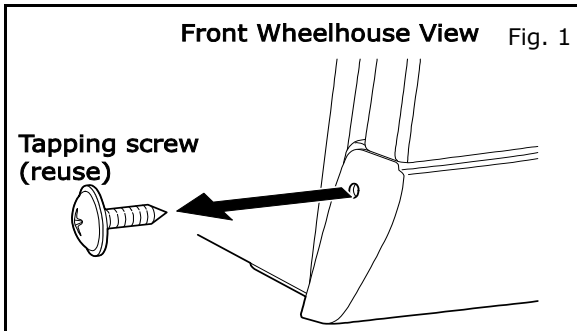

1. Installation preparation
 - a) Remove the tapping screw(reuse) in the front wheelhouse area. (1 on each side) See Fig. 1.
 - b) Remove the tapping screws(reuse) in the rear wheelhouse area. (2 on each side) See Fig. 2.
 - c) Remove the tapping screws(reuse), bolt(reuse) and clip(reuse) from underneath the standard side sill protector. (tapping screw: 6 on each side, bolts: 1 on each side, clip: 1 on each side) See Fig. 3.
 - d) Open the door.
 - e) Starting at the rear, pull outward on the standard side sill protector to remove it from the vehicle. See Fig. 4.
 - f) After removing the standard side sill protector remove any remaining clips and double-sided tape.

INSTALLATION INSTRUCTIONS - Side Sill Protector

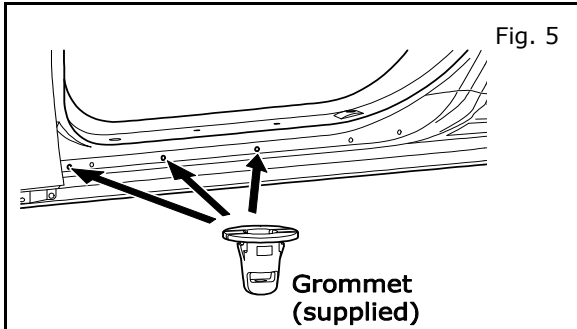

- g) After removing the side sill protector if any grommets are lost or broken, install new grommets. See Fig. 5.

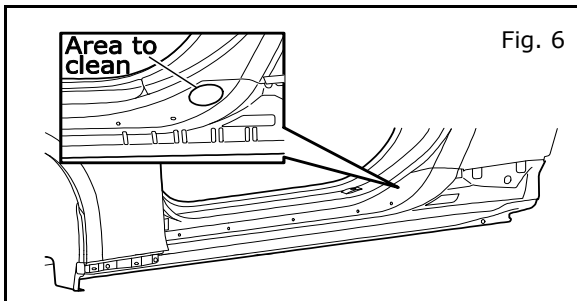

- h) Using a clean, lint free cloth and 50/50 alcohol/water solution, wipe any dirt and oil from the mounting surface. Let area dry thoroughly. See Fig. 6.

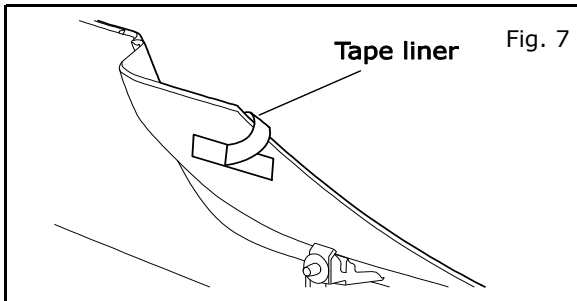

2. Accessory side sill protector installation
- a) Peel off about 30 mm of the tape liner from the double-sided tape on the side sill protector.
 - b) Fold the tape liner onto the side sill protector painted surface and apply masking tape to ensure that the tape liner is accessible. See Fig. 7.

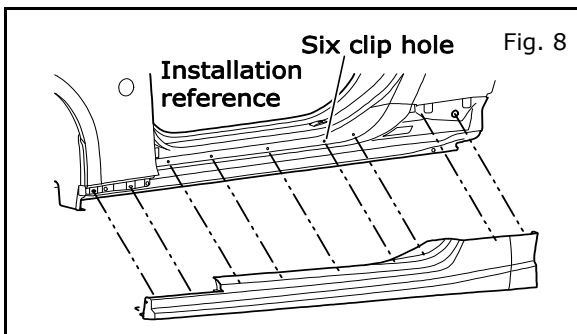

- c) Align the side sill protector clips with the holes in the vehicle body. See Fig. 8.
- d) Start at the sixth hole from the front in the vehicle body, push the side sill protector against the vehicle body to engage the sixth clip in the vehicle body hole. See Fig. 8.
- e) After the sixth clip has been engaged, engage the remaining clips in the vehicle body by pushing the side sill protector against the vehicle body.

NOTE:

IF THE BOTTOM EDGE OF THE SIDE SILL PROTECTOR INTERFERES WITH THE VEHICLE BODY, PULL DOWN ON THE BOTTOM EDGE OF THE SIDE SILL PROTECTOR UNTIL THE SIDE SILL PROTECTOR CLEARS THE VEHICLE BODY.

INSTALLATION INSTRUCTIONS - Side Sill Protector

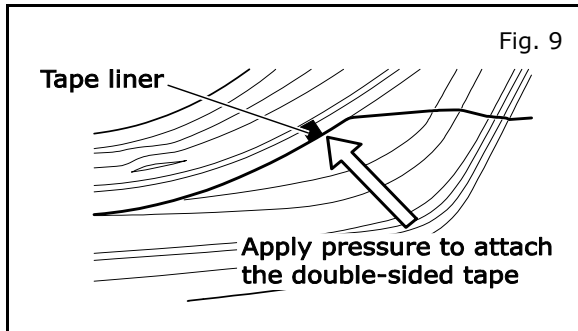

- f) Peel off the double-sided tape liner and apply at least 15lbs. of pressure to the side sill protector to ensure that the side sill protector is attached. See Fig. 9.

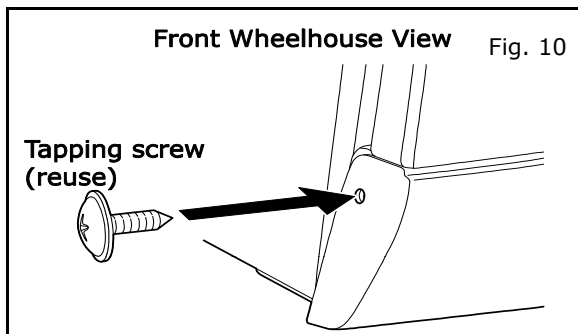

- g) Install the tapping screw(reuse) in the front wheelhouse area. (1 on each side) See Fig. 10.

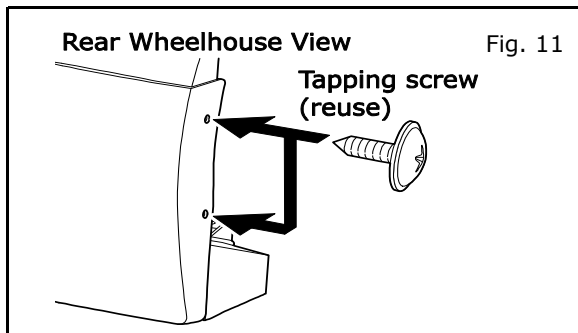

- h) Install the tapping screws(reuse) in the rear wheelhouse area. (2 on each side) See Fig. 11.

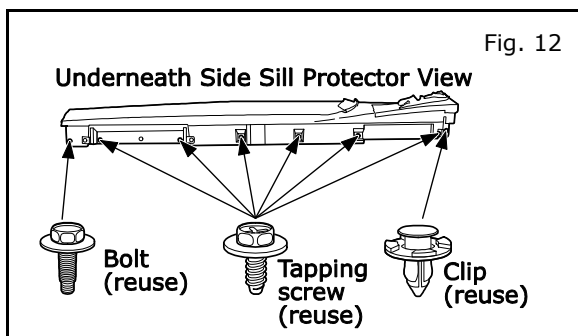

- i) Install the tapping screws(reuse), bolt(reuse) and clip(reuse) underneath the side sill protector. (tapping screws: 6 on each side, bolts: 1 on each side, clip: 1 on each side) See Fig. 12.