



nismo

INSTALLATION INSTRUCTIONS

- 1. DESCRIPTION: Front Protector**
- 2. APPLICATION: Z**
- 3. PART NUMBER: K60A0-1EAxx (xx Designates color)**
- 4. KIT CONTENTS:**

Item	Qty.	Description	Part Number
A	1	Front Protector	-
B	6	Nut - M6	-
C	10	Tapping Screw - M5	-
D	10	Spring Nut - M5	-
E	2	Front Protector End Cap	-
F	1	Paper Template - A, RH	-
G	1	Paper Template - A, LH	-
H	1	Paper Template - B, RH	-
I	1	Paper Template - B, LH	-
J	1	Installation Instructions	-

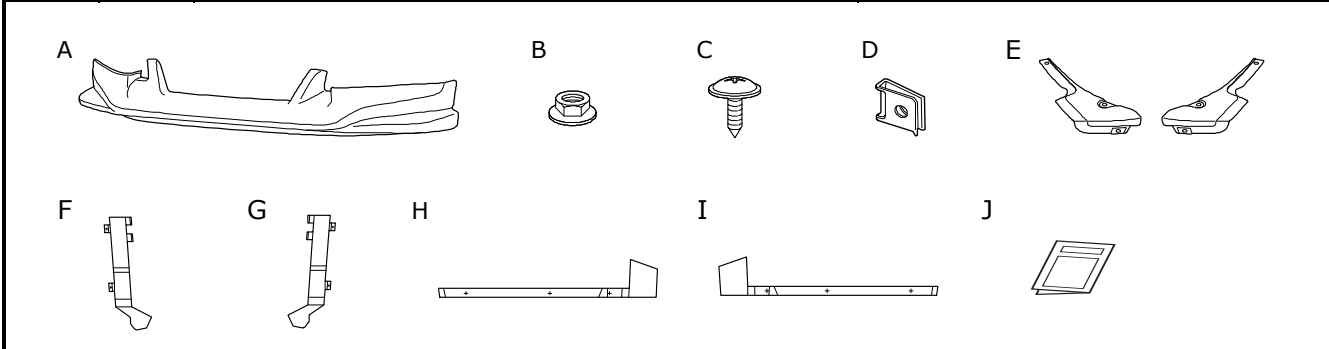

- 5. TOOLS REQUIRED:**
 - Socket wrench 10 mm (25/64")
 - Center punch
 - Masking tape
 - Clip remover
 - Drill
 - 3 mm (1/8") and 8 mm (5/16") Drill bit
 - Clean, lint-free wiping cloth
 - 50/50 alcohol/water solution
 - Stubby driver

- 6. PRE-INSTALLATION CAUTIONS/NOTES:**
- ⚠ CAUTION**
- Install the Front Protector when the ambient temperature is above 60°F (15°C).
 - Do not wash or expose the vehicle to a wet environment for 24 hours after installing the Front Protector.

NOTE

- These instructions are for the left side of the vehicle; the same procedure applies to the right side.

INSTALLATION INSTRUCTIONS - Front Protector

7. INSTALLATION PROCEDURE:

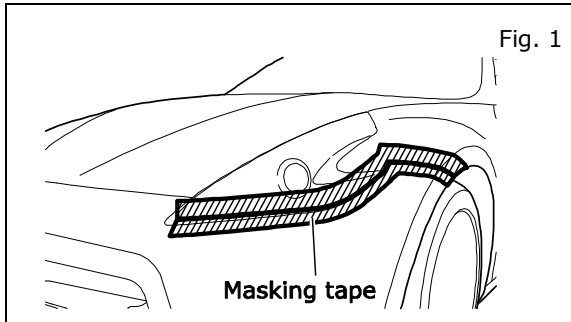

1. Installation preparation
 - a) To prevent scratches, protect the vehicle by applying masking tape. See Fig. 1.

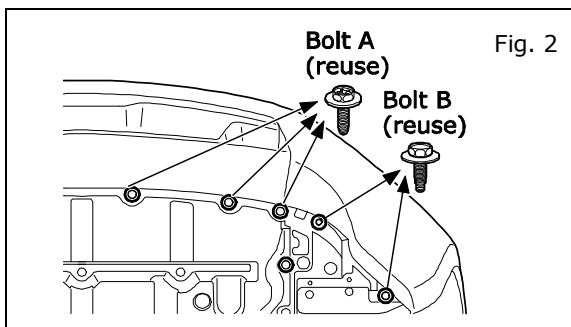

- b) Remove bolts A(reuse) and B(reuse) from under the vehicle. (bolt A: 3 on each side, bolt B: 2 on each side) See Fig. 2.

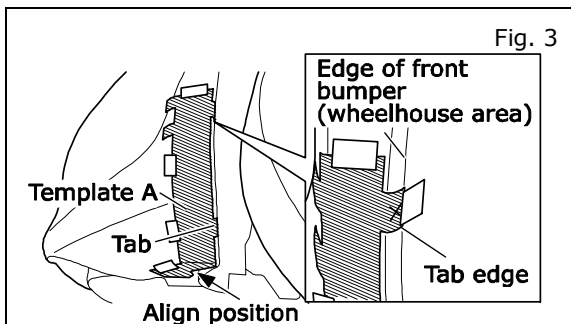

- c) Align template A to the front bumper and apply masking tape to hold the template in place. See Fig. 3.

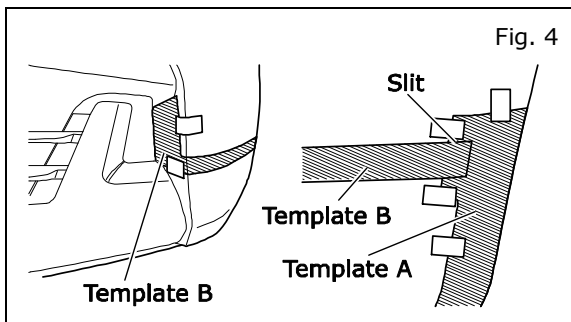

- d) Align paper template B to the front bumper opening side wall. See Fig. 4.
 - e) Align paper template B to the slit in paper template A and apply masking tape to hold the templates in place. See Fig. 4.

INSTALLATION INSTRUCTIONS - Front Protector

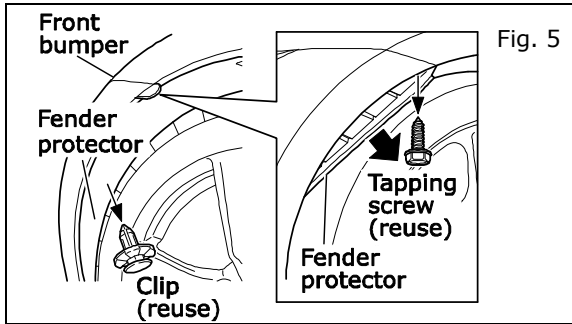

- f) Remove the clip(reuse) that attach the fender protector to the vehicle. (1 on each side) See Fig. 5.
- g) Pull the fender protector out, from behind the front bumper. See Fig. 5.
- h) Remove the tapping screw(reuse) that attach the front bumper to the fender. (1 on each side) See Fig. 5.

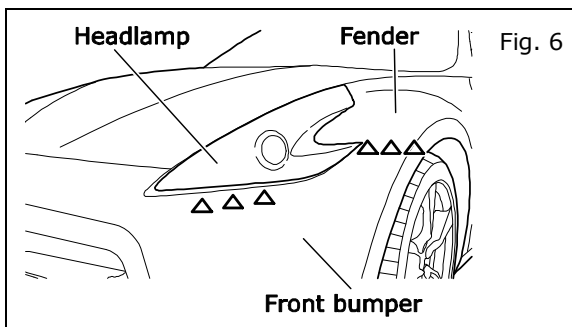

- i) Pull outward on the front bumper to detach the claws (Δ), in the fender and headlamp area, that attach the front bumper to the vehicle. See Fig. 6.

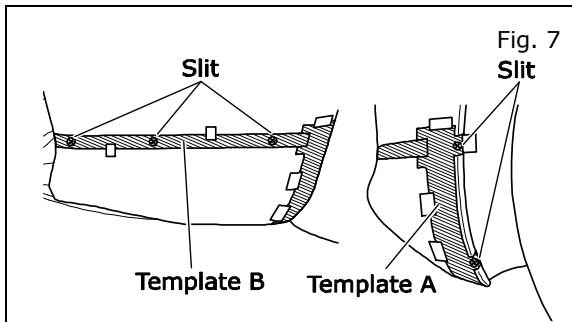

- j) Mark the hole position (+) with center punch. See Fig. 7.
- k) Remove masking tape and templates A and B.

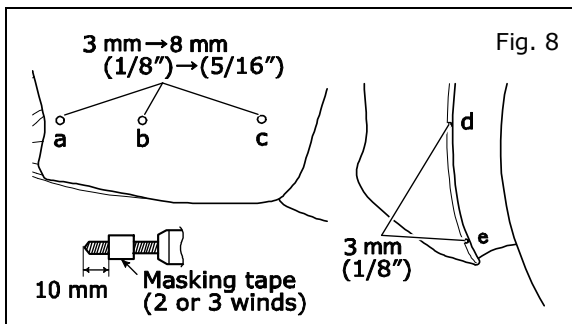

- l) Wrap masking tape around 3 mm (1/8") and 8 mm (5/16") drill bits, approximately 10 mm from the tip.
- m) Drill 3 mm (1/8") holes at the marked locations(a, b, c, d, and e) on the front bumper. See Fig 8.
- n) Drill 8 mm (5/16") holes at the marked locations(a, b, and c only) on the front bumper. See Fig 8.

INSTALLATION INSTRUCTIONS - Front Protector

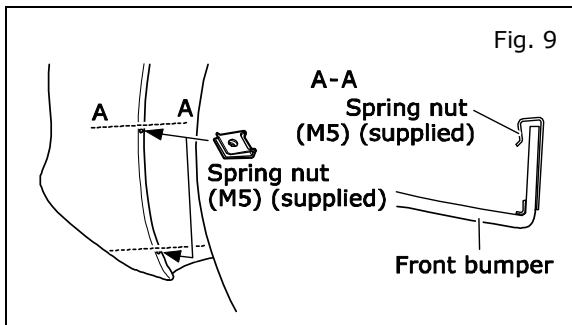

- o) Install M5 spring nuts over the 3 mm (1/8") holes in the front bumper wheelhouse area. See Fig. 9.

NOTE:
INSTALL M5 SPRING NUTS(SUPPLIED) WITH FLAT EDGE ON OUTSIDE OF THE FRONT BUMPER.

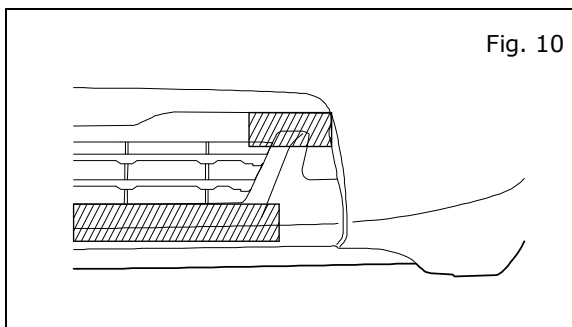

- p) Using a clean, lint free cloth and 50/50 alcohol/water solution, wipe any dirt and oil from the mounting surface. Let area dry thoroughly. See Fig 10.

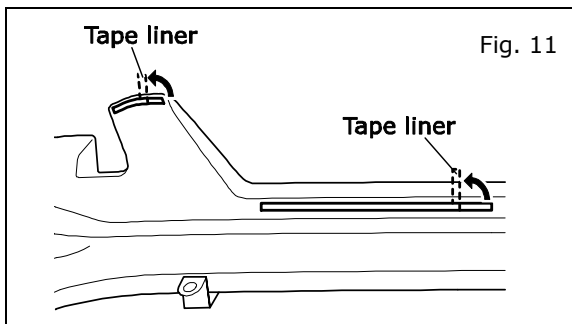

2. Front protector installation
 - a) Peel off about 30 mm of the tape liner from the double-sided tape on the front protector.
 - b) Fold the tape liner onto the front protector painted surface and apply masking tape to ensure that the tape liner is accessible. See Fig. 11.

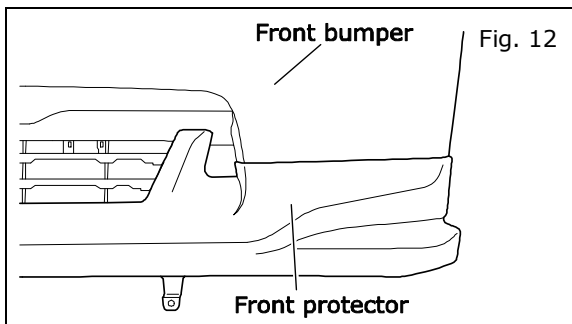

- c) Align the front protector bolts to the drilled holes in the front bumper and push the front protector against the front bumper to insert the clips in the holes.

INSTALLATION INSTRUCTIONS - Front Protector

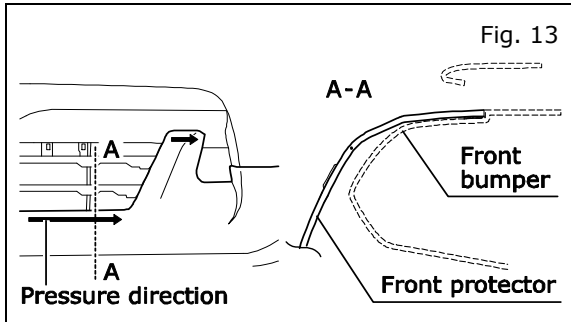

- d) Align the edge of the curved center portion of the front protector to the front bumper and hold in place. See Fig. 13.
- e) Starting at the center and moving outward, remove the double-sided tape liners and apply at least 15lbs. of pressure to the front protector to ensure that the front protector is attached. See Fig. 13.

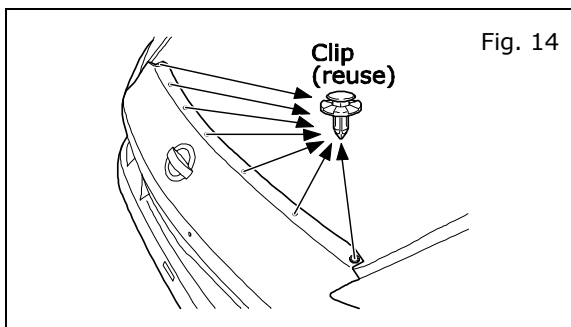

- f) Remove the clips(reuse) that attach the front bumper upper portion to the vehicle. (qty. 7) See Fig. 14.
- g) Remove the front bumper from the vehicle.

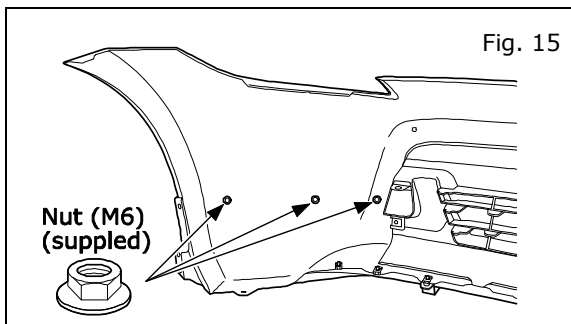

- h) Install the M6 nuts(supplied) on the front protector bolts to ensure that the front protector is attached. See Fig. 15.

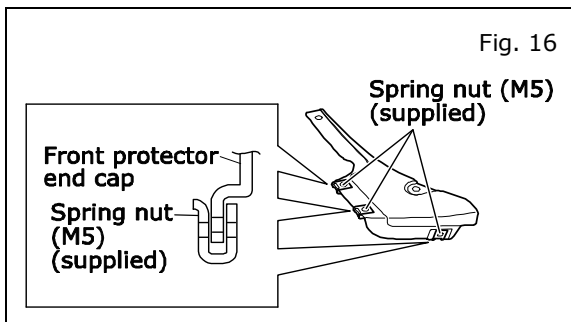

- i) Install M5 spring nuts(supplied) over the holes in the front protector end cap. (3 on each side) See Fig. 16.

NOTE:
INSTALL M5 SPRING NUTS(SUPPLIED) WITH FLAT EDGE ON OUTSIDE OF THE FRONT PROTECTOR END CAP.

INSTALLATION INSTRUCTIONS - Front Protector

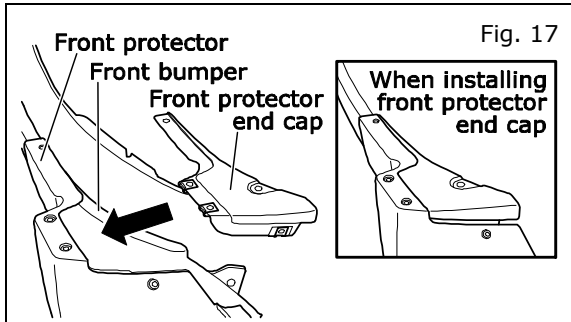

- j) Align and install the front protector end cap between the front protector and the front bumper. See fig. 17.

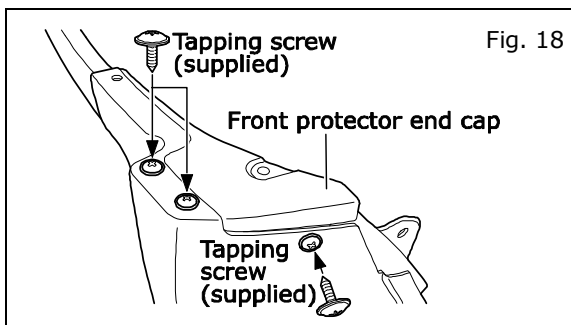

- k) Install the tapping screws (supplied). (3 on each side) See Fig. 18.

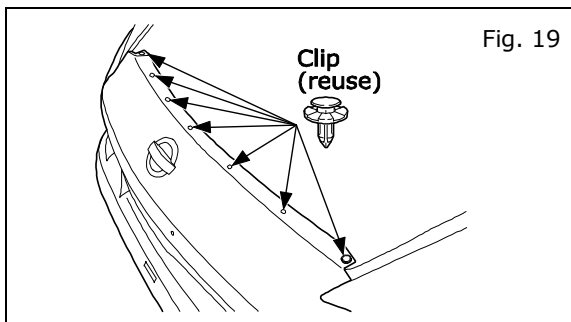

- l) Align the front bumper upper portion to the vehicle and install the clips (reuse). (qty. 7) See Fig. 19.

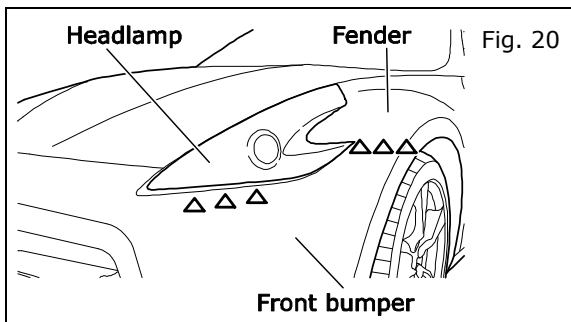

- m) Align the front bumper to the headlamp and fender and push the front bumper against the vehicle to engage the claws (Δ), in the fender and headlamp area. See Fig. 20.

INSTALLATION INSTRUCTIONS - Front Protector

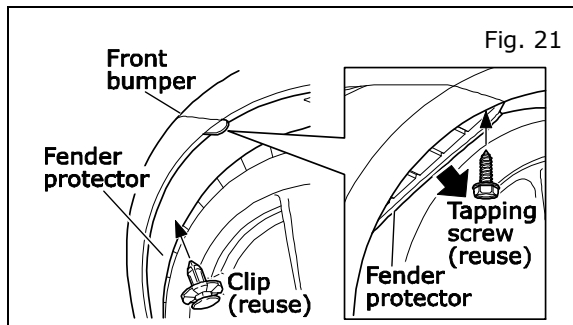

- n) Align and install the fender protector to the inside of the front bumper. See Fig. 21.
- o) Install the tapping screw(reuse) that attach the front bumper to the fender. (1 on each side) See Fig. 21.
- p) Install the clip(reuse) that attach the fender protector to the vehicle. (1 on each side) See Fig. 21.

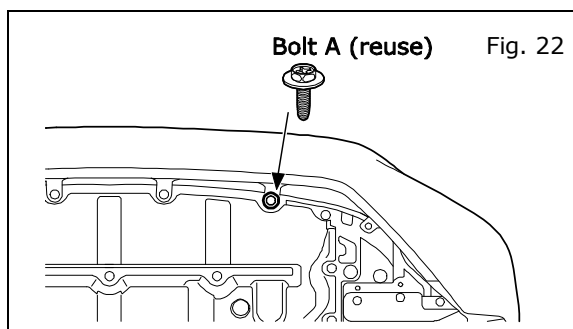

- q) Align the front protector hinge, under the vehicle, to the front bumper and install the bolt A(reuse). (1 on each side) See Fig. 22.

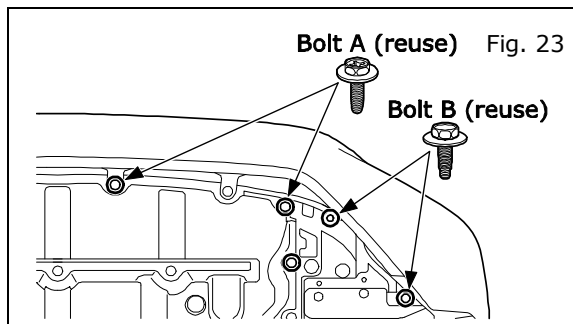

- r) Install bolts A(reuse) and B(reuse) under the vehicle. (bolt A: 2 on each side, bolt B: 1 on each side) See Fig. 23.

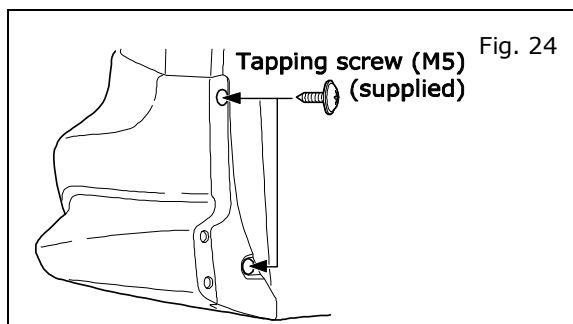

- s) Install the tapping screws(reuse) in the front wheelhouse area. (2 on each side) See Fig. 24.