



SERVICE BULLETIN

Classification: EC98-001f	Reference: NTB98-018f	Date: November 7, 2012
------------------------------	--------------------------	---------------------------

SYSTEM READINESS TEST (SRT) DRIVE PATTERNS

**This bulletin has been amended. Several Changes were made on page 9.
Please discard all previous versions of this bulletin.**

APPLIED VEHICLES: 1996 and newer Model Years as required by State Emissions Inspections Regulations.

SERVICE INFORMATION

As part of an enhanced emissions test for Inspection & Maintenance (I/M), some States may require the System Readiness Test (SRT) status be checked.

- The SRT is used to indicate whether the engine control module (ECM) has completed self diagnosis of major emissions systems and components.
- In these instances the State may require completion of the SRT before permitting the emissions inspection to proceed.

The State Emissions Inspection Station may advise a Nissan customer to return to the dealership for service due to one or more SRT items coming up **“INCOMPLETE.”** Use the information in this Bulletin to help you **“COMPLETE”** the SRT.

- In most cases the ECM will automatically complete its self diagnosis cycle during normal vehicle usage, and the SRT status will indicate **“COMPLETE”** for each applicable system.
- Once indicating **“COMPLETE,”** the SRT status remains **“COMPLETE”** until the Self Diagnosis memory is erased.
- Occasionally, certain portions of the self diagnostic test may not be completed as a result of the customer’s normal driving pattern. In these cases the SRT will indicate **“INCOMPLETE”** for these items.

NOTE: The SRT will also indicate **“INCOMPLETE”** if:

- The self diagnosis memory is erased for any reason, or
- The ECM memory power supply is interrupted for several hours.

Nissan Bulletins are intended for use by qualified technicians, not 'do-it-yourselfers'. Qualified technicians are properly trained individuals who have the equipment, tools, safety instruction, and know-how to do a job properly and safely. **NOTE:** If you believe that a described condition may apply to a particular vehicle, **DO NOT** assume that it does. See your Nissan dealer to determine if this applies to your vehicle.

This bulletin contains information to help you perform a comprehensive road test (Drive Pattern) that enables the ECM to complete the SRT.

- A separate Drive Pattern sheet for each 1996 and 1997 vehicle variation is included with this Bulletin.
- For 1998 and newer vehicles, refer to the EC section of the appropriate Service Manual for the required Drive Pattern. They are listed under On Board Diagnostic > System Readiness Test.

NOTE: You must select the Drive Pattern that correctly corresponds with all variables for the vehicle being serviced (i.e. model, model year, engine, emissions certification, transmission, powertrain, and for 1996/1997 models, ECM part number).

NOTE: To ensure all ECM Self Test requirements are met, it is important to drive the entire Drive Pattern even if only one SRT item indicates "INCOMPLETE."

CLAIMS INFORMATION:

Refer to the current Warranty Flat Rate Manual for claims information.

SERVICE PROCEDURE

SRT WORKFLOW

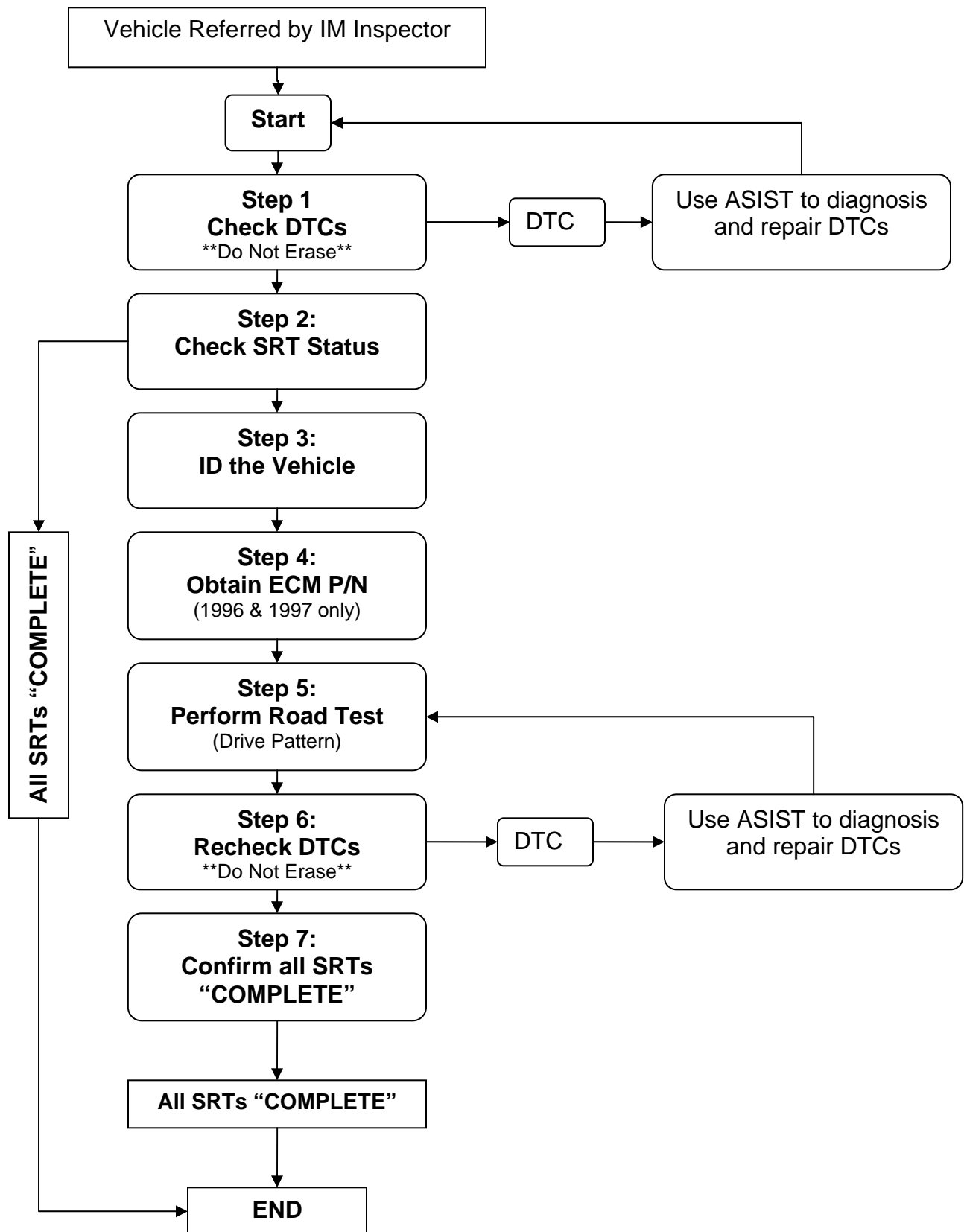

Step 1: Check for DTC

1. Use a CONSULT tool to check for any stored DTCs.
 - If any DTCs are stored they must be repaired at this time.
 - Refer to ASIST for diagnostic and repair information.

NOTE: Normal warranty coverage will apply for DTC repairs.

2. If no DTCs are stored, go to the next step.

NOTE: DO NOT touch “Erase” or you will lose previously completed SRTs.

Step 2: Check SRT Status

Check the SRT Status (Complete or Incomplete).

- Use the appropriate CONSULT tool.
- For older vehicles, a Generic Scan Tool may be needed to check SRT status.

NOTE: In some cases, the normal driving that occurs between the time the vehicle was referred by the State Emissions Inspection Station and it is brought into the dealership for SRT evaluation may allow the ECM to complete the SRTs. If this occurs, no further action is necessary.

Always check SRT status before performing the SRT Drive Pattern.

Step 3: Identify the Vehicle

You must select the Drive Pattern that correctly corresponds with all variables for the vehicle being serviced:

Model_____

Model Year_____

Engine_____

Emissions certification_____

- Some models have different drive patterns depending on the emissions certification (i.e. California, Federal, 50 State).
- Check the under hood emissions label to determine the emissions certification for the vehicle being inspected.

Transmission_____

Powertrain (2WD or 4WD) _____

For 1996/1997 models, ECM part number)_____

Step 4: Obtain ECM Part Number (1996 and 1997 models only)

1. Use a CONSULT tool to obtain the ECM part number.
2. Write the ECM part number in the space provided above.
3. Compare the vehicles ECM part number with the list of ECM part numbers provided in the Nissan SRT System Chart (page 10) to determine the Drive Pattern for the vehicle being inspected.

NOTE: For 1996 and 1997 models; if the vehicles ECM part number does not match a part number listed on the SRT System Chart for that vehicle, either 1) the vehicle was identified incorrectly or 2) the vehicle has the wrong ECM installed. The SRT cannot be completed with the incorrect ECM.

Step 5: SRT Road Test (perform Drive Pattern)

To properly obtain SRT readings of “**COMPLETE**,” it is necessary to drive the vehicle under the exact conditions required by the vehicle’s ECM.

Be sure to select the correct Drive Pattern. The SRTs will not complete if the wrong drive pattern for that vehicle is used.

1. Select the Drive Pattern based on the Vehicle Identification (see Step 3).
 - For 1996 and 1997 vehicles:
 - This bulletin contains a specific Driving Pattern for every 1996 and 1997 Nissan vehicle.
 - Use the “Bookmark” on the left side of the ASIST screen to choose the correct model and year.
 - Verify that the vehicle ECM P/N matches EXACTLY an ECM P/N listed on the Drive Pattern sheet you chose.
 - Print the Drive Pattern to take with you.
 - For 1998 and newer vehicles, refer to the EC section in the appropriate Service Manual for the required Drive Pattern. It is listed under On-Board Diagnostics > System Readiness Test.
 - Print the Drive Pattern to take with you.
2. Prior to driving the vehicle, review the Drive Pattern and prepare to complete it from start to finish:
 - Review the Pre-Check items listed on the drive pattern and ensure all conditions are met.
 - Determine the vehicle speeds required by the drive pattern.
 - Plan your route to minimize traffic and traffic signals that might interrupt the Drive Pattern tasks.
 - Review the Drive Pattern section(s) that must be restarted if you are interrupted.
 - Do not use the ASCD (cruise control) during any section of the Drive Pattern that contains the “No ASCD” symbol.
 - Some EVAP-equipped vehicles will require that fuel be added to the tank between the first and second trip. Be prepared to purchase fuel or plan your route to accommodate this step.
 - For these EVAP-equipped vehicles, begin the road test with less than ½ tank of fuel. If the fuel level is greater than ½, more time may be required to complete the EVAP sections of the Drive Pattern and you may not be able to add fuel as required.

Step 5: SRT Road Test (continued)

3. Review the Drive Pattern for any input signals that need to be monitored during the drive.
 - If needed, Connect a CONSULT tool to the vehicle to monitor required signals.

NOTE:

- Monitor the Fuel Temperature if the EVAP SRT is “**INCOMPLETE.**” One part of the EVAP SRT diagnostic logic requires a 3°C increase in fuel temperature from the time the ignition key is turned to “ON” as part of the test criteria. Fluctuations in the fuel temperature reading can extend the time required for the EVAP SRT to indicate “**COMPLETE.**” If the fuel temperature change is not sufficient after completing the SRT Drive pattern, idle the vehicle until a fuel temperature increase of at least 3°C is noted or until the EVAP SRT indicates “**COMPLETE.**”
 - If the fuel temperature increases 3°C or more but the SRT still indicates “**INCOMPLETE,**” the SRT Drive Pattern may need to be repeated.
4. Note the following items before starting the Drive Pattern:
 - **IMPORTANT:** Nissan requires using a driver and an assistant to conduct SRT driving patterns. The assistant should read the Drive Pattern, CONSULT data, and drive time and convey driving instruction to the driver. It is the driver’s responsibility to observe and react to traffic conditions. **Always drive the vehicle in a safe manner and obey all traffic laws.**
 - To ensure all ECM Self Test requirements are met, drive the ENTIRE pattern whenever any SRT items indicate “**INCOMPLETE.**”
 - Some vehicles require that sections of the Drive Pattern be driven two times to satisfy the “self diagnosis two trip logic”. For vehicles that require two trips, the pre-check engine coolant temperature must be met before beginning Section 1 of the second trip.

5. Perform the Drive Pattern:

- a. Make sure all Pre-Check conditions are met.
- b. Drive the vehicle and carefully follow the specific instructions and time requirements listed in each section of the Drive Pattern.

NOTE: If you monitor the (B/FUEL SCHDL):

- The Base Fuel Schedule (B/FUEL SCHDL) is an indication of engine load.
- It will be easier to match high B/FUEL SCHDL values when driving up slight hills in the recommended gear range.
- It will be easier to match low B/FUEL SCHDL values when driving down slight hills in the recommended gear range.
- Turning the A/C compressor ON will increase the B/FUEL SCHDL value, while turning it OFF will decrease the B/FUEL SCHDL value.

Step 6: Recheck for DTC

Upon completion of the Drive Pattern, determine if any DTCs have been stored. Only in rare cases will this occur.

- If a DTC has been stored after completing the Drive Pattern, it must be repaired. Refer to ASIST for diagnostic and repair information.

NOTE: Normal warranty coverage will apply for DTC repairs.

- Once the DTC is repaired, erase the stored DTC. Turn the ignition OFF for 10 seconds, and then repeat the entire Drive Pattern (**Step 5**) to “COMPLETE” the SRTs.
- If no DTCs have been stored, **DO NOT touch “Erase” or all SRT items will reset to “INCOMPLETE.”**

Step 7: Confirm All SRTs “COMPLETE”

If all SRT items indicate “COMPLETE,” the inspection is complete.

- If Catalyst and/or O2 Sensor Monitors show “INCOMPLETE” perform step A or B below.
 - A. Check Self Learning Value and A/F ALPHA. If either value is +10% or more above target of 100%, clear Self Learning Value.
 - Perform DTC diagnosis for P0171 or P0174 and check for the following possible causes:
 - Intake air leaks
 - Front heated oxygen sensors
 - Injectors
 - Exhaust gas leaks
 - Incorrect fuel pressure
 - Lack of fuel
 - Mass air flow sensor
 - A. Check Self Learning Value and A/F ALPHA. If either value is -10% or more below target of 100%, clear Self Learning Value.
 - Perform DTC diagnosis for P0172 or P0175 and check for the following possible causes:
 - Intake air leaks
 - Front heated oxygen sensors
 - Injectors
 - Exhaust gas leaks
 - Incorrect fuel pressure
 - Lack of fuel
 - Mass air flow sensor
- After repairs have been made, run the prescribed drive pattern and check that A/F ALPHA is within $\pm 10\%$ of the target of 100% during the steady state portions of the drive cycle. If it is not, then continue repairs. If it is, return to STEP 5.

Nissan SRT System Chart (page 1)

				1 trip or 2 trip SRT					
Model	Model Year	T/M	ECM Part No.23710-XXXXX	Drive Pattern	EGR	O ₂ Heater	O ₂ Sensor	Catalyst	EVAP
Altima (Fed)	'96	M/T	5E400, 5E401, 5E402, 5E403, 5E404	1	1 trip	N/A	1 trip	1 trip	N/A
		A/T	5E410, 5E411, 5E412, 5E413, 5E414	2					
Altima (Cal)	'96	M/T	5E500	3	1 trip	1 trip	1 trip	1 trip	N/A
			5E501, 5E502, 5E503, 5E504	4	2 trip	2 trip	2 trip	2 trip	N/A
Altima (Cal)	'96	A/T	5E510	5	1 trip	1 trip	1 trip	1 trip	N/A
			5E511, 5E512, 5E513, 5E514	6	2 trip	2 trip	2 trip	2 trip	N/A
Altima	'97	M/T	5E700, 5E701, 5E702, 5E703, 5E704, 5E705, 5E720, 5E721, 5E722, 5E723, 5E724, 5E725	7	2 trip	2 trip	2 trip	2 trip	N/A
		A/T	5E710, 5E711, 5E712, 5E713, 5E714, 5E715, 5E760, 5E761, 5E762, 5E763, 5E764, 5E765	8					
	'97.5	M/T	5E800, 5E801, 5E802, 5E803, 5E804, 5E810, 5E811, 5E812, 5E813, 5E814, 5E860, 5E870	9					
		A/T	5E805, 5E806, 5E807, 5E808, 5E809, 5E815, 5E816, 5E817, 5E818, 5E819, 5E865, 5E875	10					
Maxima	'96	M/T	54U00, 54U01, 54U02, 54U03, 54U04, 54U05, 54U06, 56U60, 56U61, 56U62, 56U63, 56U64, 56U66	11	1 trip	1 trip	1 trip	1 trip	2 trip
		A/T	54U10, 54U11, 54U12, 54U13, 54U14, 54U15, 54U16, 56U70, 56U71, 56U72, 56U73, 56U74, 56U76	12					
	'97	M/T	0L700, 0L701, 0L702, 0L707, 0L708, 0L709, 0L760, 0L761, 0L762, 0L767, 0L768, 0L769	13	2 trip	2 trip	2 trip	2 trip	2 trip
		A/T	0L710, 0L711, 0L712, 0L717, 0L718, 0L719, 0L770, 0L771, 0L772, 0L777, 0L778, 0L779	14					
Pathfinder	'96	M/T	0W000, 0W005, 0W060, 0W061, 0W063	15	1 trip	1 trip	1 trip	1 trip	N/A
		A/T	0W010, 0W015, 0W065, 0W066, 0W067, 0W069	16					
	'97	M/T	1W200, 1W201, 1W202, 1W203, 1W204, 1W260, 1W262	17	2 trip	2 trip	2 trip	2 trip	2 trip
		A/T	1W205, 1W206, 1W207, 1W208, 1W209, 1W265, 1W266, 1W268	18					
Quest	'96	A/T	1B000, 1B001, 1B002	19	1 trip	1 trip	1 trip	1 trip	N/A
	'97		1B010, 1B011, 1B012, 1B013, 1B014	20	2 trip	2 trip	2 trip	2 trip	N/A
Sentra-20 OSX (GA16)	'96	M/T	0M220, 0M221, 0M224, 0M262, 0M263, 0M269, 0M270, 0M271, 0M272, 0M273, 0M274, 1M214, 1M217, 1M222, 1M565, 1M566	21	1 trip	1 trip	1 trip	1 trip	N/A
			0M260, 0M261, 0M264, 0M279, 0M282, 0M283, 1M204, 1M216, 1M221, 1M520, 1M521	22	1 trip	N/A	1 trip	1 trip	N/A
	A/T	0M222, 0M223, 0M265, 0M266, 0M267, 0M268, 0M275, 0M276, 0M277, 0M278, 0M280, 0M284, 1M219, 1M223, 1M275, 1M575, 1M576, 1M580, 1M581	23	1 trip	1 trip	1 trip	1 trip	N/A	
	'97	M/T	3M200, 3M202, 3M203, 3M204, 3M205, 3M206, 3M207, 3M208, 3M209, 3M260, 3M261, 3M270, 3M271, 3M300, 3M302, 3M303, 3M304, 3M305, 3M306, 3M307, 3M308, 3M309, 3M360, 3M361, 3M370, 3M371	24	2 trip	2 trip	2 trip	2 trip	2 trip
A/T		3M210, 3M212, 3M213, 3M214, 3M215, 3M216, 3M217, 3M218, 3M219, 3M265, 3M266, 3M275, 3M276, 3M310, 3M312, 3M313, 3M314, 3M315, 3M316, 3M317, 3M318, 3M319, 3M365, 3M366, 3M375, 3M376	25						

Nissan SRT System Chart (page 2)

Model	Model Year	T/M	ECM Part No.23710-XXXXX	1 trip or 2 trip SRT						
				Drive Pattern	EGR	O ₂ Heater	O ₂ Sensor	Catalyst	EVAP	
200SX (SR20)	'96/'97	M/T	1M860, 1M861, 1M870, 1M871, 1M872	26	1 trip	1 trip	1 trip	1 trip	N/A	
	'96/'97	A/T	1M865, 1M866, 1M875, 1M876, 1M877	27						
Truck (2WD)	'96	M/T	1S700, 1S701, 1S702, 1S703	28	1 trip	1 trip	1 trip	1 trip	1 trip	
			1S300, 1S301, 1S306, 1S307, 1S704, 1S706, 1S708, 1S709, 1S717, 1S718, 1S719, 1S720, 1S721, 1S722, 1S723, 1S724	29	2 trip	2 trip	2 trip	2 trip	2 trip	
		A/T	1S710, 1S712	30	1 trip	1 trip	1 trip	1 trip	1 trip	
			1S302, 1S303, 1S308, 1S713, 1S714, 1S716, 1S768, 1S770, 1S771, 1S772, 1S781, 1S782	31	2 trip	2 trip	2 trip	2 trip	2 trip	
	'97	M/T	1S300, 1S301, 1S306, 1S307, 1S308, 1S704, 1S706, 1S708, 1S709, 1S717, 1S718, 1S719, 1S720, 1S721, 1S722, 1S723, 1S724,	32	2 trip	2 trip	2 trip	2 trip	2 trip	
		A/T	1S302, 1S303, 1S710, 1S712, 1S713, 1S714, 1S716, 1S768, 1S770, 1S771, 1S772, 1S781, 1S782	33						
Truck (4WD)	'96	M/T	1S760, 1S761, 1S762, 1S763	34	1 trip	1 trip	1 trip	1 trip	1 trip	
			1S304, 1S305, 1S309, 1S310, 1S764, 1S766, 1S769, 1S774, 1S775, 1S776, 1S777, 1S778, 1S779, 1S780, 1S784, 1S783	35	2 trip	2 trip	2 trip	2 trip	2 trip	
	'97	M/T	1S304, 1S305, 1S309, 1S310, 1S764, 1S766, 1S769, 1S774, 1S775, 1S776, 1S777, 1S778, 1S779, 1S780, 1S783, 1S784	36	2 trip	2 trip	2 trip	2 trip	2 trip	
240SX	'96	M/T	72F00, 72F01, 72F02, 72F03, 72F04, 72F05	37	1 trip	1 trip	1 trip	1 trip	2 trip	
		A/T	72F10, 72F11, 71F12, 72F13, 72F14, 72F15	38						
	'97	M/T	81F00, 81F01, 81F02, 81F03	39	2 trip	2 trip	2 trip	2 trip	2 trip	
		A/T	81F10, 81F11, 81F12, 81F13	40						
300ZX (Non-turbo)	'96	M/T	54P60, 54P61	41	1 trip	1 trip	1 trip	1 trip	N/A	
			54P74, 54P62	42	2 trip	2 trip	2 trip	2 trip	N/A	
		A/T	54P65, 54P66	43	1 trip	1 trip	1 trip	1 trip	N/A	
			54P75, 54P67	44	2 trip	2 trip	2 trip	2 trip	N/A	
300ZX (Turbo)	'96	M/T	54P00, 54P01, 54P02, 54P03, 54P70, 54P04	45	1 trip	1 trip	1 trip	1 trip	N/A	
		A/T	54P05, 54P06, 54P07, 54P08, 54P71, 54P09	46						

Note: SRT Items highlighted in gray indicate the drive pattern section for that item must be repeated if the trip is interrupted by releasing the throttle when not directed to do so.

No gray highlight indicates the drive pattern for that SRT item will resume at point of interruption if the drive pattern for that SRT item is interrupted by releasing the throttle when not directed to do so.

SRT DRIVE PATTERN LAYOUT

Drive Pattern Number
(referenced on system chart)

SRT Address ('96 only)
Enter this number into
CONSULT Address
Setting mode.

ECM Part Number
Always check vehicle ECM
part number with CONSULT
and match to this list.

TRIP
Drive & Pattern sections
required for each trip.

Drive Time Requirements
Drive vehicle and meet conditions
listed for the time period indicated.
If interrupted, increase drive time
or repeat section as directed.

Increase & decrease road speed
as indicated by drive pattern lines.
Select level roads for best results.

Use CONSULT Data Monitor to
ensure Pre-check conditions are
met prior to starting section 1.

Use CONSULT in Data
Monitor to display values.
Match specifications
while driving vehicle.

Read and follow all notes.

NOTE: Select level roads whenever possible.

System Readiness Test Drive Pattern #12

SRT Status Address: 1000
ECM Part Numbers: 23710-54U10, -54U11, -54U12, -54U13, -54U14, -54U15, -54U16, -54U17, -54U18, -54U19, -54U20, -54U21, -54U22, -54U23, -54U24, -54U25, -54U26, -54U27, -54U28, -54U29, -54U30, -54U31, -54U32, -54U33, -54U34, -54U35, -54U36, -54U37, -54U38, -54U39, -54U40, -54U41, -54U42, -54U43, -54U44, -54U45, -54U46, -54U47, -54U48, -54U49, -54U50, -54U51, -54U52, -54U53, -54U54, -54U55, -54U56, -54U57, -54U58, -54U59, -54U60, -54U61, -54U62, -54U63, -54U64, -54U65, -54U66, -54U67, -54U68, -54U69, -54U70, -54U71, -54U72, -54U73, -54U74, -54U75, -54U76, -54U77, -54U78, -54U79, -54U80, -54U81, -54U82, -54U83, -54U84, -54U85, -54U86, -54U87, -54U88, -54U89, -54U90, -54U91, -54U92, -54U93, -54U94, -54U95, -54U96, -54U97, -54U98, -54U99, -54U100, -54U101, -54U102, -54U103, -54U104, -54U105, -54U106, -54U107, -54U108, -54U109, -54U110, -54U111, -54U112, -54U113, -54U114, -54U115, -54U116, -54U117, -54U118, -54U119, -54U120, -54U121, -54U122, -54U123, -54U124, -54U125, -54U126, -54U127, -54U128, -54U129, -54U130, -54U131, -54U132, -54U133, -54U134, -54U135, -54U136, -54U137, -54U138, -54U139, -54U140, -54U141, -54U142, -54U143, -54U144, -54U145, -54U146, -54U147, -54U148, -54U149, -54U150, -54U151, -54U152, -54U153, -54U154, -54U155, -54U156, -54U157, -54U158, -54U159, -54U160, -54U161, -54U162, -54U163, -54U164, -54U165, -54U166, -54U167, -54U168, -54U169, -54U170, -54U171, -54U172, -54U173, -54U174, -54U175, -54U176, -54U177, -54U178, -54U179, -54U180, -54U181, -54U182, -54U183, -54U184, -54U185, -54U186, -54U187, -54U188, -54U189, -54U190, -54U191, -54U192, -54U193, -54U194, -54U195, -54U196, -54U197, -54U198, -54U199, -54U200, -54U201, -54U202, -54U203, -54U204, -54U205, -54U206, -54U207, -54U208, -54U209, -54U210, -54U211, -54U212, -54U213, -54U214, -54U215, -54U216, -54U217, -54U218, -54U219, -54U220, -54U221, -54U222, -54U223, -54U224, -54U225, -54U226, -54U227, -54U228, -54U229, -54U230, -54U231, -54U232, -54U233, -54U234, -54U235, -54U236, -54U237, -54U238, -54U239, -54U240, -54U241, -54U242, -54U243, -54U244, -54U245, -54U246, -54U247, -54U248, -54U249, -54U250, -54U251, -54U252, -54U253, -54U254, -54U255, -54U256, -54U257, -54U258, -54U259, -54U260, -54U261, -54U262, -54U263, -54U264, -54U265, -54U266, -54U267, -54U268, -54U269, -54U270, -54U271, -54U272, -54U273, -54U274, -54U275, -54U276, -54U277, -54U278, -54U279, -54U280, -54U281, -54U282, -54U283, -54U284, -54U285, -54U286, -54U287, -54U288, -54U289, -54U290, -54U291, -54U292, -54U293, -54U294, -54U295, -54U296, -54U297, -54U298, -54U299, -54U300, -54U301, -54U302, -54U303, -54U304, -54U305, -54U306, -54U307, -54U308, -54U309, -54U310, -54U311, -54U312, -54U313, -54U314, -54U315, -54U316, -54U317, -54U318, -54U319, -54U320, -54U321, -54U322, -54U323, -54U324, -54U325, -54U326, -54U327, -54U328, -54U329, -54U330, -54U331, -54U332, -54U333, -54U334, -54U335, -54U336, -54U337, -54U338, -54U339, -54U340, -54U341, -54U342, -54U343, -54U344, -54U345, -54U346, -54U347, -54U348, -54U349, -54U350, -54U351, -54U352, -54U353, -54U354, -54U355, -54U356, -54U357, -54U358, -54U359, -54U360, -54U361, -54U362, -54U363, -54U364, -54U365, -54U366, -54U367, -54U368, -54U369, -54U370, -54U371, -54U372, -54U373, -54U374, -54U375, -54U376, -54U377, -54U378, -54U379, -54U380, -54U381, -54U382, -54U383, -54U384, -54U385, -54U386, -54U387, -54U388, -54U389, -54U390, -54U391, -54U392, -54U393, -54U394, -54U395, -54U396, -54U397, -54U398, -54U399, -54U400, -54U401, -54U402, -54U403, -54U404, -54U405, -54U406, -54U407, -54U408, -54U409, -54U410, -54U411, -54U412, -54U413, -54U414, -54U415, -54U416, -54U417, -54U418, -54U419, -54U420, -54U421, -54U422, -54U423, -54U424, -54U425, -54U426, -54U427, -54U428, -54U429, -54U430, -54U431, -54U432, -54U433, -54U434, -54U435, -54U436, -54U437, -54U438, -54U439, -54U440, -54U441, -54U442, -54U443, -54U444, -54U445, -54U446, -54U447, -54U448, -54U449, -54U450, -54U451, -54U452, -54U453, -54U454, -54U455, -54U456, -54U457, -54U458, -54U459, -54U460, -54U461, -54U462, -54U463, -54U464, -54U465, -54U466, -54U467, -54U468, -54U469, -54U470, -54U471, -54U472, -54U473, -54U474, -54U475, -54U476, -54U477, -54U478, -54U479, -54U480, -54U481, -54U482, -54U483, -54U484, -54U485, -54U486, -54U487, -54U488, -54U489, -54U490, -54U491, -54U492, -54U493, -54U494, -54U495, -54U496, -54U497, -54U498, -54U499, -54U500, -54U501, -54U502, -54U503, -54U504, -54U505, -54U506, -54U507, -54U508, -54U509, -54U510, -54U511, -54U512, -54U513, -54U514, -54U515, -54U516, -54U517, -54U518, -54U519, -54U520, -54U521, -54U522, -54U523, -54U524, -54U525, -54U526, -54U527, -54U528, -54U529, -54U530, -54U531, -54U532, -54U533, -54U534, -54U535, -54U536, -54U537, -54U538, -54U539, -54U540, -54U541, -54U542, -54U543, -54U544, -54U545, -54U546, -54U547, -54U548, -54U549, -54U550, -54U551, -54U552, -54U553, -54U554, -54U555, -54U556, -54U557, -54U558, -54U559, -54U560, -54U561, -54U562, -54U563, -54U564, -54U565, -54U566, -54U567, -54U568, -54U569, -54U570, -54U571, -54U572, -54U573, -54U574, -54U575, -54U576, -54U577, -54U578, -54U579, -54U580, -54U581, -54U582, -54U583, -54U584, -54U585, -54U586, -54U587, -54U588, -54U589, -54U590, -54U591, -54U592, -54U593, -54U594, -54U595, -54U596, -54U597, -54U598, -54U599, -54U600, -54U601, -54U602, -54U603, -54U604, -54U605, -54U606, -54U607, -54U608, -54U609, -54U610, -54U611, -54U612, -54U613, -54U614, -54U615, -54U616, -54U617, -54U618, -54U619, -54U620, -54U621, -54U622, -54U623, -54U624, -54U625, -54U626, -54U627, -54U628, -54U629, -54U630, -54U631, -54U632, -54U633, -54U634, -54U635, -54U636, -54U637, -54U638, -54U639, -54U640, -54U641, -54U642, -54U643, -54U644, -54U645, -54U646, -54U647, -54U648, -54U649, -54U650, -54U651, -54U652, -54U653, -54U654, -54U655, -54U656, -54U657, -54U658, -54U659, -54U660, -54U661, -54U662, -54U663, -54U664, -54U665, -54U666, -54U667, -54U668, -54U669, -54U670, -54U671, -54U672, -54U673, -54U674, -54U675, -54U676, -54U677, -54U678, -54U679, -54U680, -54U681, -54U682, -54U683, -54U684, -54U685, -54U686, -54U687, -54U688, -54U689, -54U690, -54U691, -54U692, -54U693, -54U694, -54U695, -54U696, -54U697, -54U698, -54U699, -54U700, -54U701, -54U702, -54U703, -54U704, -54U705, -54U706, -54U707, -54U708, -54U709, -54U710, -54U711, -54U712, -54U713, -54U714, -54U715, -54U716, -54U717, -54U718, -54U719, -54U720, -54U721, -54U722, -54U723, -54U724, -54U725, -54U726, -54U727, -54U728, -54U729, -54U730, -54U731, -54U732, -54U733, -54U734, -54U735, -54U736, -54U737, -54U738, -54U739, -54U740, -54U741, -54U742, -54U743, -54U744, -54U745, -54U746, -54U747, -54U748, -54U749, -54U750, -54U751, -54U752, -54U753, -54U754, -54U755, -54U756, -54U757, -54U758, -54U759, -54U760, -54U761, -54U762, -54U763, -54U764, -54U765, -54U766, -54U767, -54U768, -54U769, -54U770, -54U771, -54U772, -54U773, -54U774, -54U775, -54U776, -54U777, -54U778, -54U779, -54U780, -54U781, -54U782, -54U783, -54U784, -54U785, -54U786, -54U787, -54U788, -54U789, -54U790, -54U791, -54U792, -54U793, -54U794, -54U795, -54U796, -54U797, -54U798, -54U799, -54U800, -54U801, -54U802, -54U803, -54U804, -54U805, -54U806, -54U807, -54U808, -54U809, -54U810, -54U811, -54U812, -54U813, -54U814, -54U815, -54U816, -54U817, -54U818, -54U819, -54U820, -54U821, -54U822, -54U823, -54U824, -54U825, -54U826, -54U827, -54U828, -54U829, -54U830, -54U831, -54U832, -54U833, -54U834, -54U835, -54U836, -54U837, -54U838, -54U839, -54U840, -54U841, -54U842, -54U843, -54U844, -54U845, -54U846, -54U847, -54U848, -54U849, -54U850, -54U851, -54U852, -54U853, -54U854, -54U855, -54U856, -54U857, -54U858, -54U859, -54U860, -54U861, -54U862, -54U863, -54U864, -54U865, -54U866, -54U867, -54U868, -54U869, -54U870, -54U871, -54U872, -54U873, -54U874, -54U875, -54U876, -54U877, -54U878, -54U879, -54U880, -54U881, -54U882, -54U883, -54U884, -54U885, -54U886, -54U887, -54U888, -54U889, -54U890, -54U891, -54U892, -54U893, -54U894, -54U895, -54U896, -54U897, -54U898, -54U899, -54U900, -54U901, -54U902, -54U903, -54U904, -54U905, -54U906, -54U907, -54U908, -54U909, -54U910, -54U911, -54U912, -54U913, -54U914, -54U915, -54U916, -54U917, -54U918, -54U919, -54U920, -54U921, -54U922, -54U923, -54U924, -54U925, -54U926, -54U927, -54U928, -54U929, -54U930, -54U931, -54U932, -54U933, -54U934, -54U935, -54U936, -54U937, -54U938, -54U939, -54U940, -54U941, -54U942, -54U943, -54U944, -54U945, -54U946, -54U947, -54U948, -54U949, -54U950, -54U951, -54U952, -54U953, -54U954, -54U955, -54U956, -54U957, -54U958, -54U959, -54U960, -54U961, -54U962, -54U963, -54U964, -54U965, -54U966, -54U967, -54U968, -54U969, -54U970, -54U971, -54U972, -54U973, -54U974, -54U975, -54U976, -54U977, -54U978, -54U979, -54U980, -54U981, -54U982, -54U983, -54U984, -54U985, -54U986, -54U987, -54U988, -54U989, -54U990, -54U991, -54U992, -54U993, -54U994, -54U995, -54U996, -54U997, -54U998, -54U999, -54U1000.

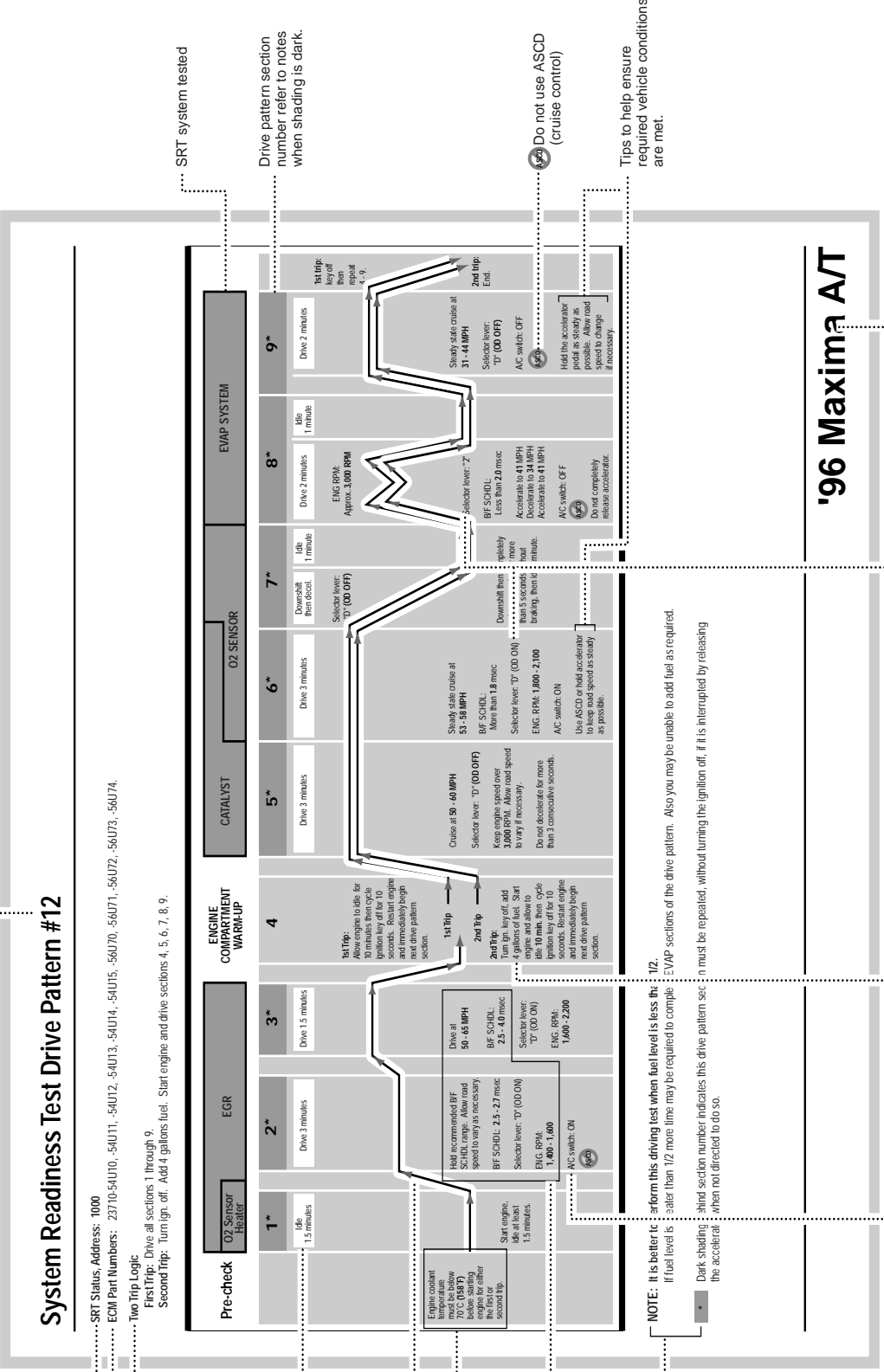

Vehicle Identification
Always match vehicle and
ECM part number to correct
drive pattern sheet.

Gear position necessary
to obtain RPM range and
B/FUEL SCHDL.

Add fuel when directed

A/C switch
ON - adds engine load to increase B/FUEL SCHDL.
OFF - Lowers engine load to decrease B/FUEL SCHDL.

Tips to help ensure
required vehicle conditions
are met.

Do not use ASCD
(cruise control)

Drive pattern section
number refer to notes
when shading is dark.

SRT system tested

NOTE: It is better to
perform this driving test when fuel level is less than
1/2. If fuel level is greater than 1/2, more time may be required to complete
E/VAP sections of the drive pattern. Also you may be unable to add fuel as required.
Dark shading indicates this drive pattern section must be repeated, without turning the ignition off, if it is interrupted by releasing
the accelerator when not directed to do so.

System Readiness Test Drive Pattern #1

ECM Part Numbers: 23710-5E400, -5E401, -5E402, -5E403, -5E404

One Trip Logic for all sections.
Drive all sections one time.

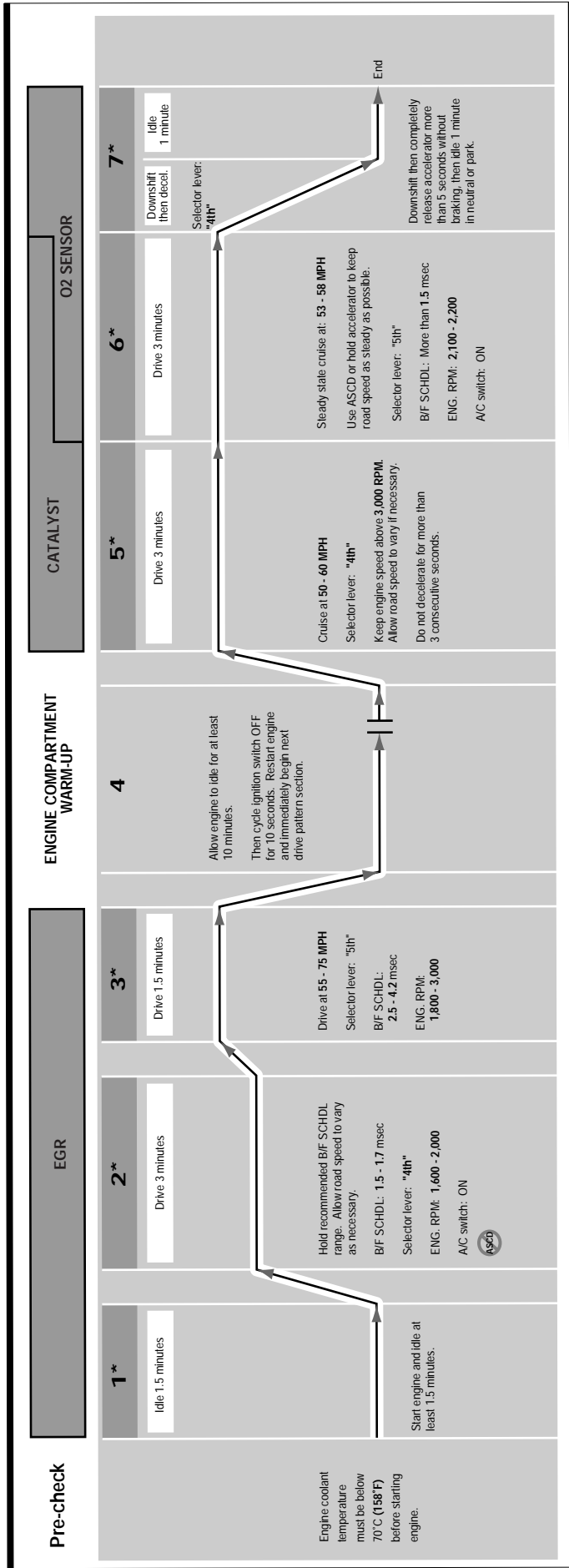

* Dark shading behind section number indicates this drive pattern section must be repeated, without turning the ignition off, if it is interrupted by releasing the accelerator when not directed to do so.

'96 Altima (FED) M/T

System Readiness Test Drive Pattern #2

ECM Part Numbers: 23710-5E410, -5E411, -5E412, -5E413, -5E414

One Trip Logic for all sections.
Drive all sections one time.

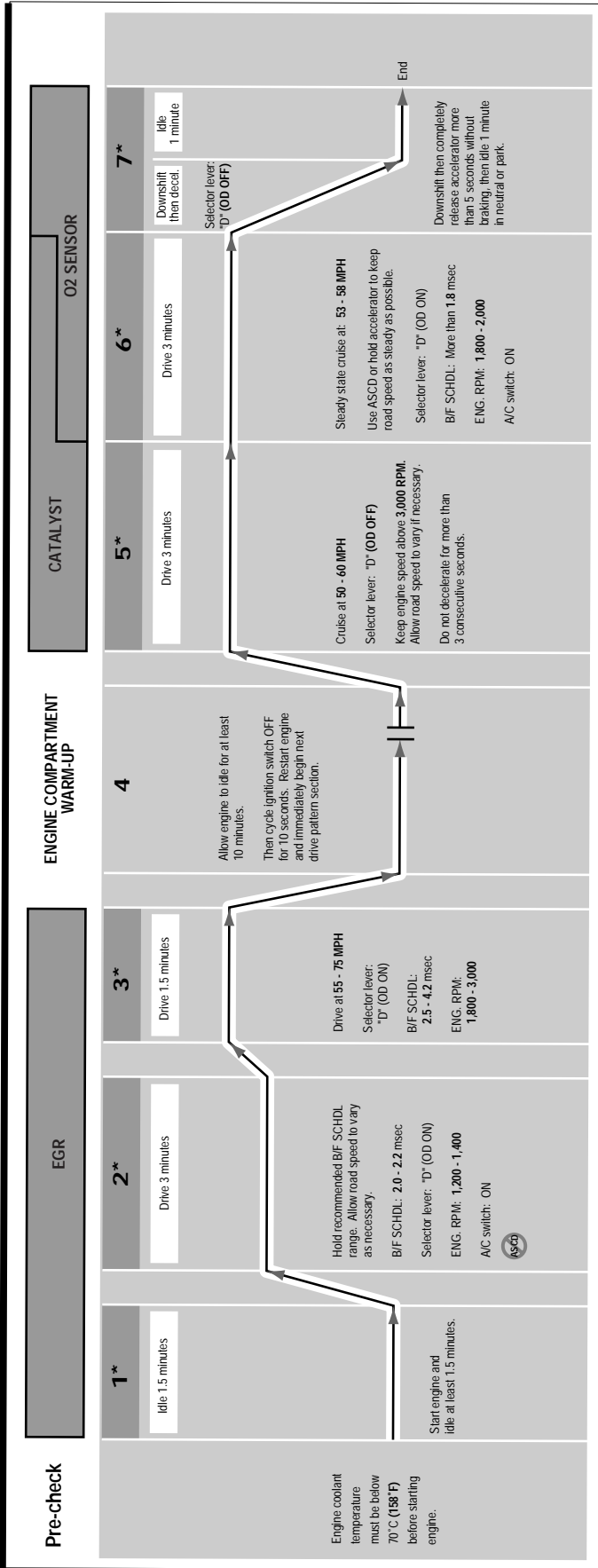

System Readiness Test Drive Pattern #3

ECM Part Numbers: 23710-5E500

One Trip Logic for all sections.
Drive all sections one time.

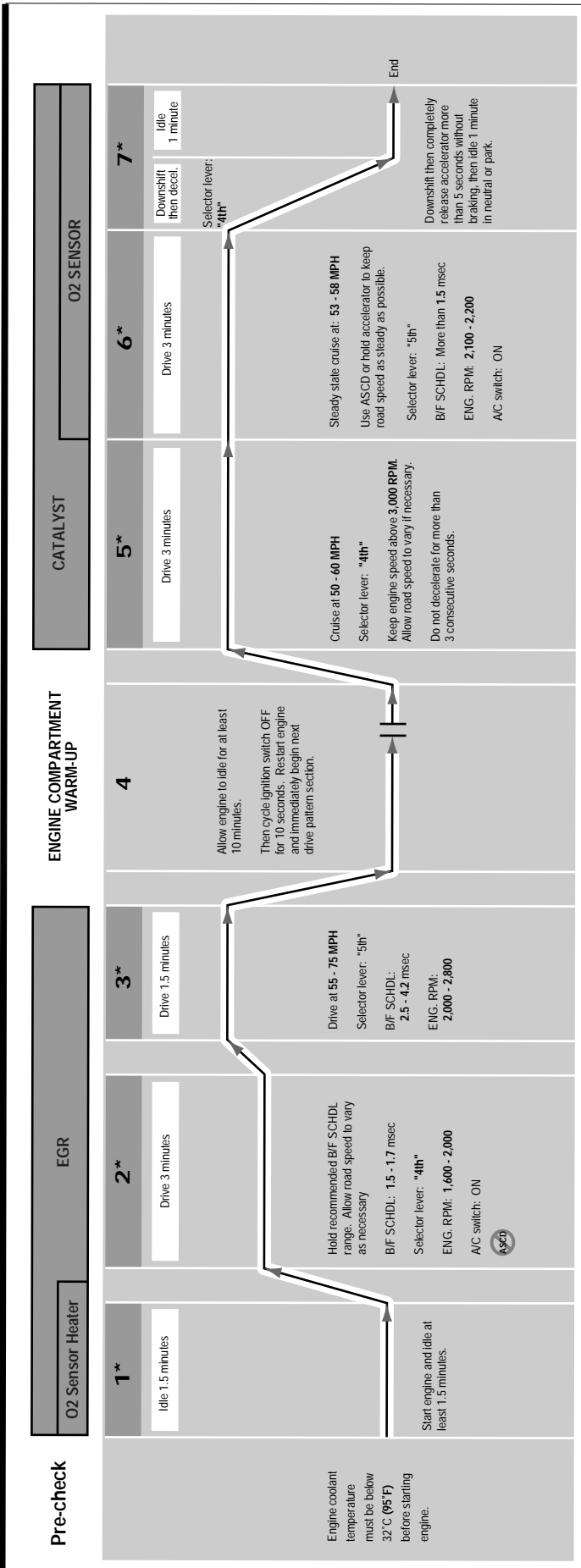

* Dark shading behind section number indicates this drive pattern section must be repeated, without turning the ignition off, if it is interrupted by releasing the accelerator when not directed to do so.

System Readiness Test Drive Pattern #4

ECM Part Numbers: 23710-5E501, -5E502, -5E503, -5E504

Two Trip Logic (all sections)

1st Trip: Drive 1 through 6, then turn ign. off and allow engine to cool to 158° F.

2nd Trip: Drive sections 1 through 6 again.

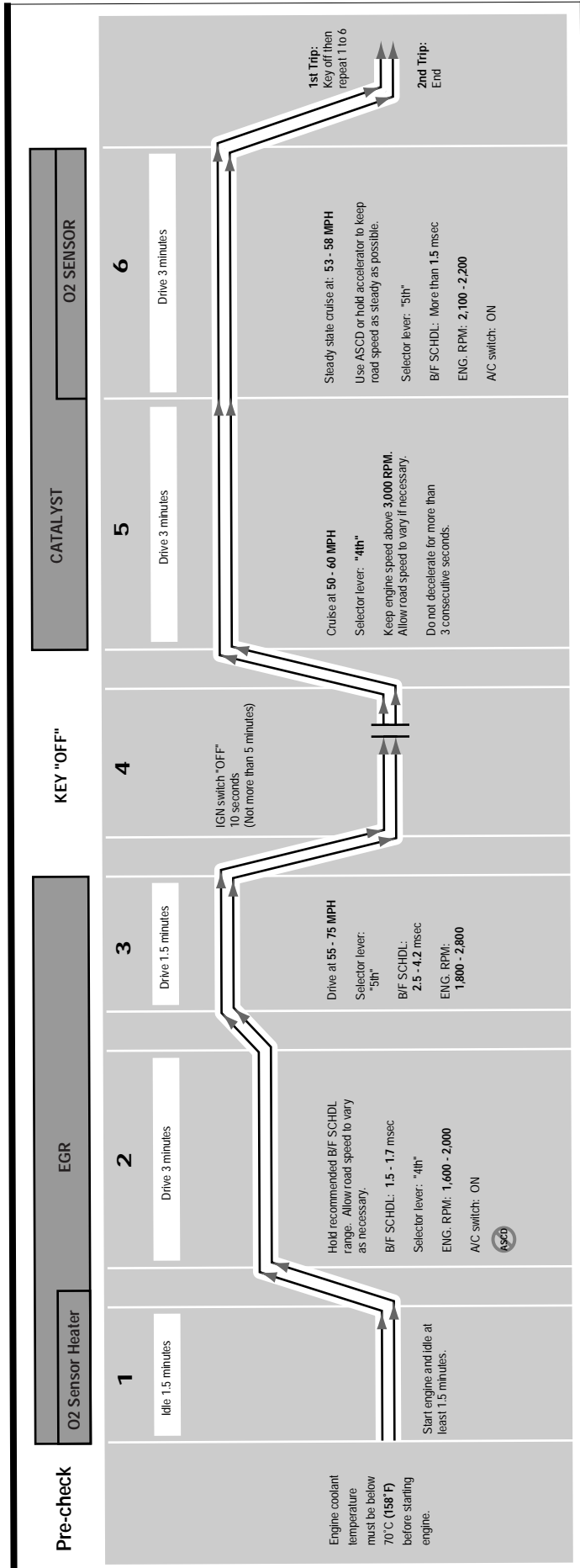

'96 Altima (CAL) M/T

System Readiness Test Drive Pattern #5

ECM Part Numbers: 23710-5E510

One Trip Logic for all sections.
Drive all sections one time.

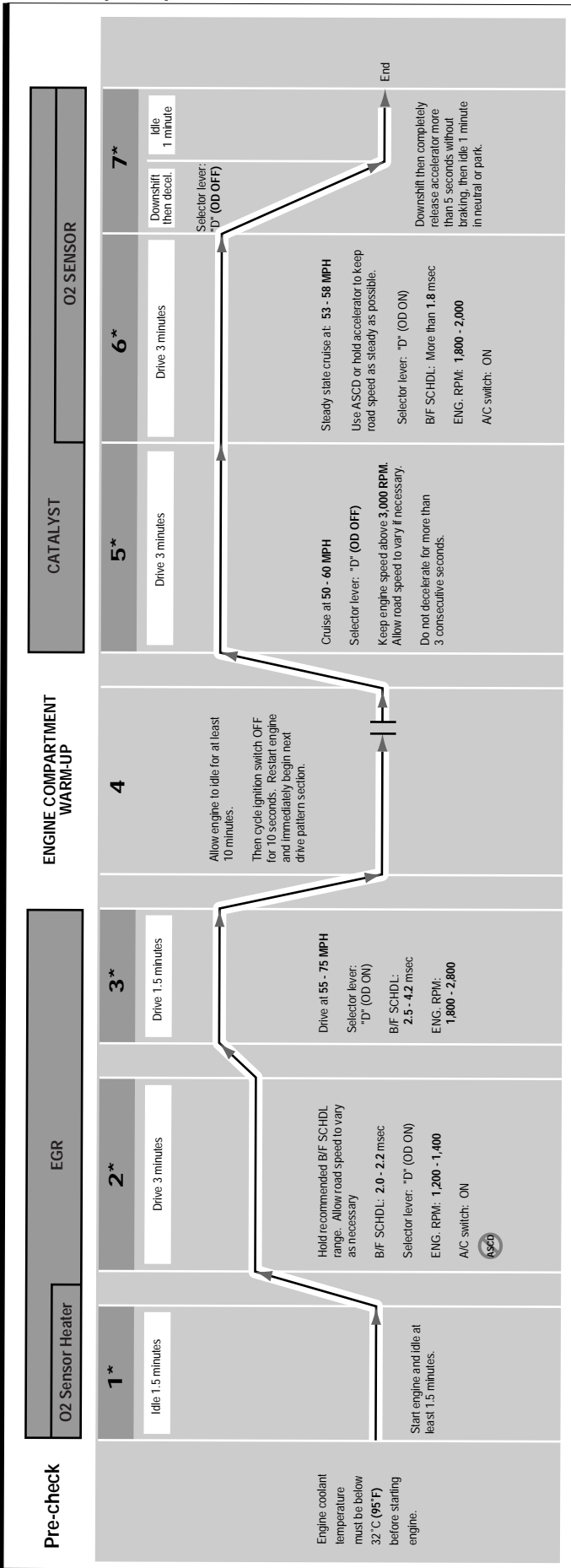

* Dark shading behind section number indicates this drive pattern section must be repeated, without turning the ignition off, if it is interrupted by releasing the accelerator when not directed to do so.

System Readiness Test Drive Pattern #6

ECM Part Numbers: 23710-5E511, -5E512, -5E513, -5E514

Two Trip Logic (all sections)

1st Trip: Drive 1 through 6, then turn ign. off and allow engine to cool to 158°F.

2nd Trip: Drive sections 1 through 6 again.

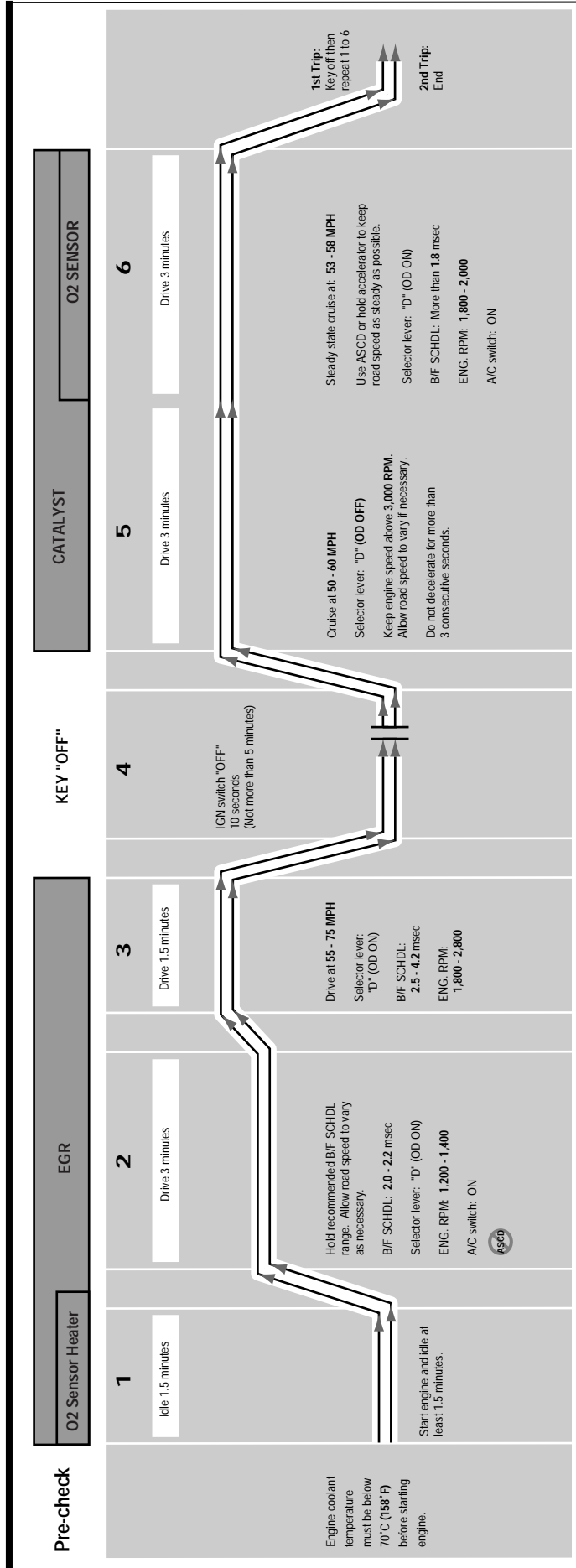

'96 Altima (CAL) A/T

System Readiness Test Drive Pattern #7

ECM Part Numbers: 23710-5E700, -5E701, -5E702, -5E703, -5E704, -5E705, -5E720, -5E721, -5E722, -5E723, -5E724, -5E725

Two Trip Logic (all sections)

1st Trip: Drive 1 through 6, then turn ign. off and allow engine to cool to 158°F.

2nd Trip: Drive sections 1 through 6 again.

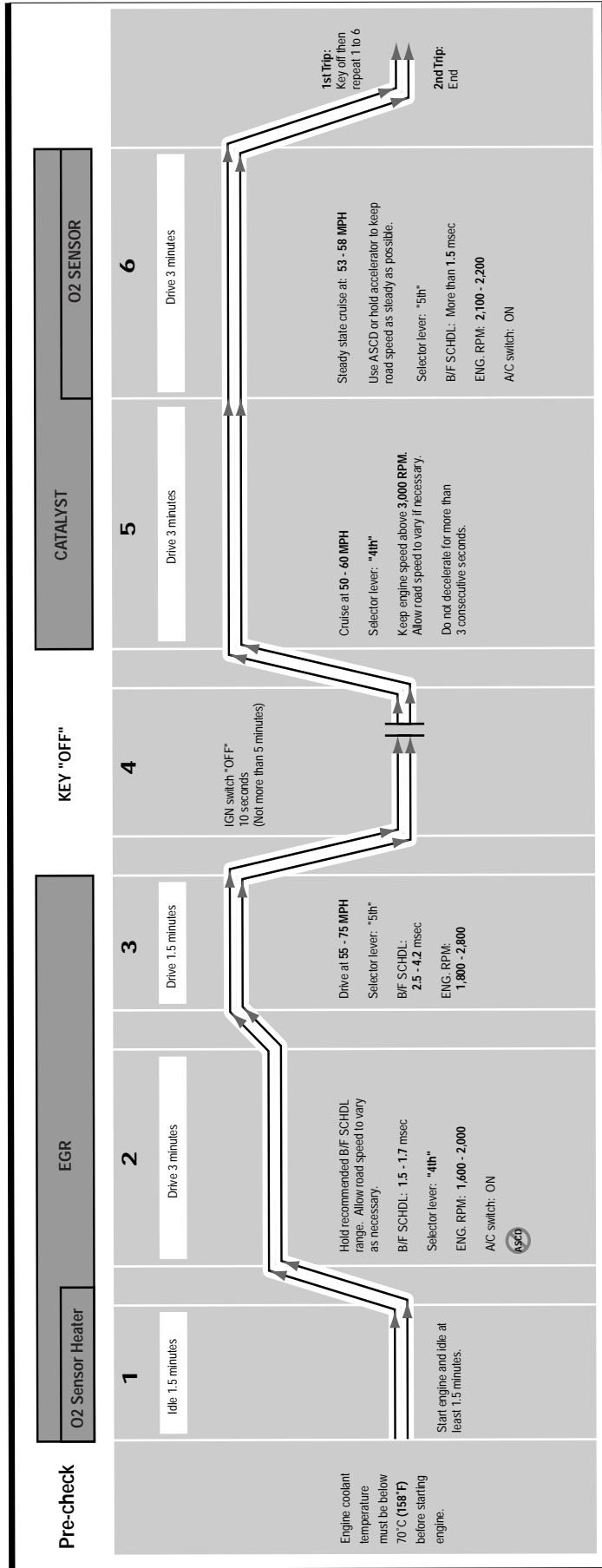

System Readiness Test Drive Pattern #8

ECM Part Numbers: 23710-5E710, -5E711, -5E712, -5E713, -5E714, -5E715, -5E760, -5E761, -5E762, -5E763, -5E764, -5E765

Two Trip Logic (all sections)

1st Trip: Drive 1 through 6, then turn ign. off and allow engine to cool to 158°F.

2nd Trip: Drive sections 1 through 6 again.

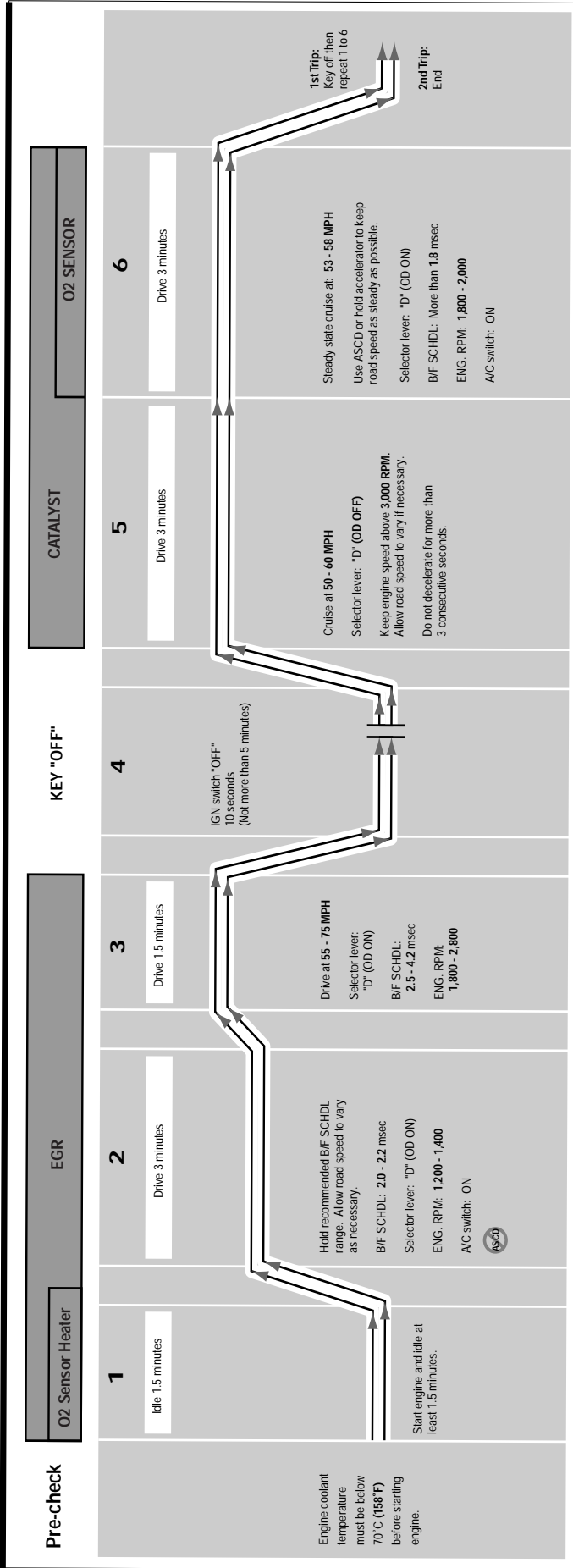

System Readiness Test Drive Pattern #9

ECM Part Numbers: 23710-5E800, -5E801, -5E802, -5E803, -5E804, -5E810, -5E811, -5E812, -5E813, -5E814, -5E860, -5E870

Two Trip Logic (all sections)

1st Trip: Drive 1 through 6, then turn ign. off and allow engine to cool to 158°F.

2nd Trip: Drive sections 1 through 6 again.

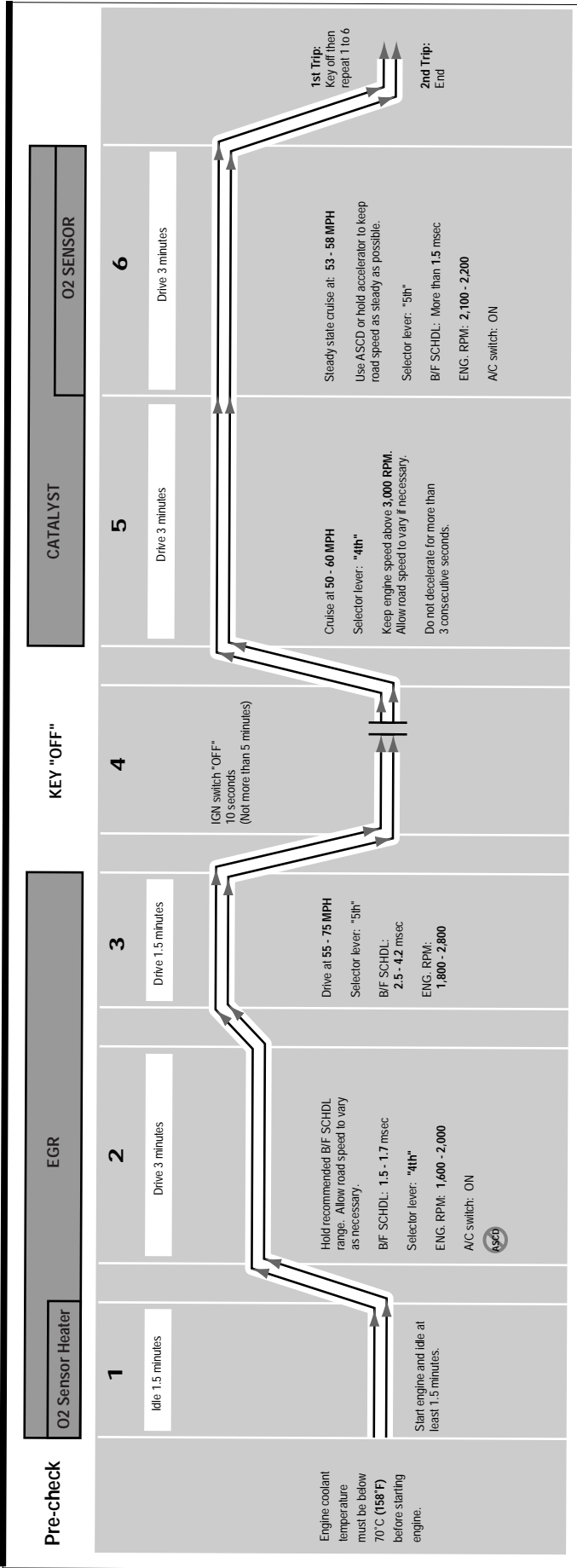

System Readiness Test Drive Pattern #10

ECM Part Numbers: 23710-5E805, -5E806, -5E807, -5E808, -5E809, -5E815, -5E816, -5E817, -5E818, -5E819, 5E865, -5E875

Two Trip Logic (all sections)

1st Trip: Drive 1 through 6, then turn ign. off and allow engine to cool to 158°F.

2nd Trip: Drive sections 1 through 6 again.

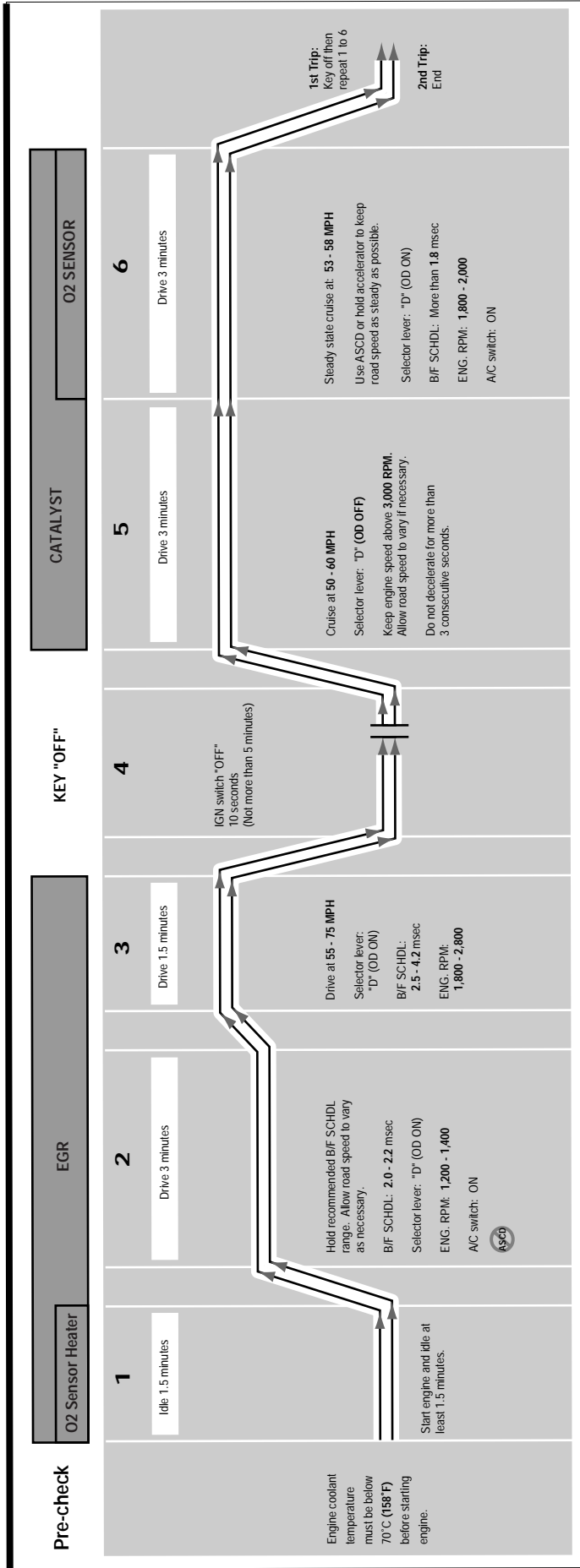

'97.5 Altima A/T

System Readiness Test Drive Pattern #11

ECM Part Numbers: 23710-54U00, -54U01, -54U02, -54U03, -54U04, -54U05, -54U06, -56U60, -56U61, -56U62, -56U63, -56U64, -56U66

Two Trip Logic

First Trip: Drive all sections 1 through 9.

Second Trip: Turn ign. off. Add 4 gallons fuel. Start engine and drive sections 4, 5, 6, 7, 8, 9.

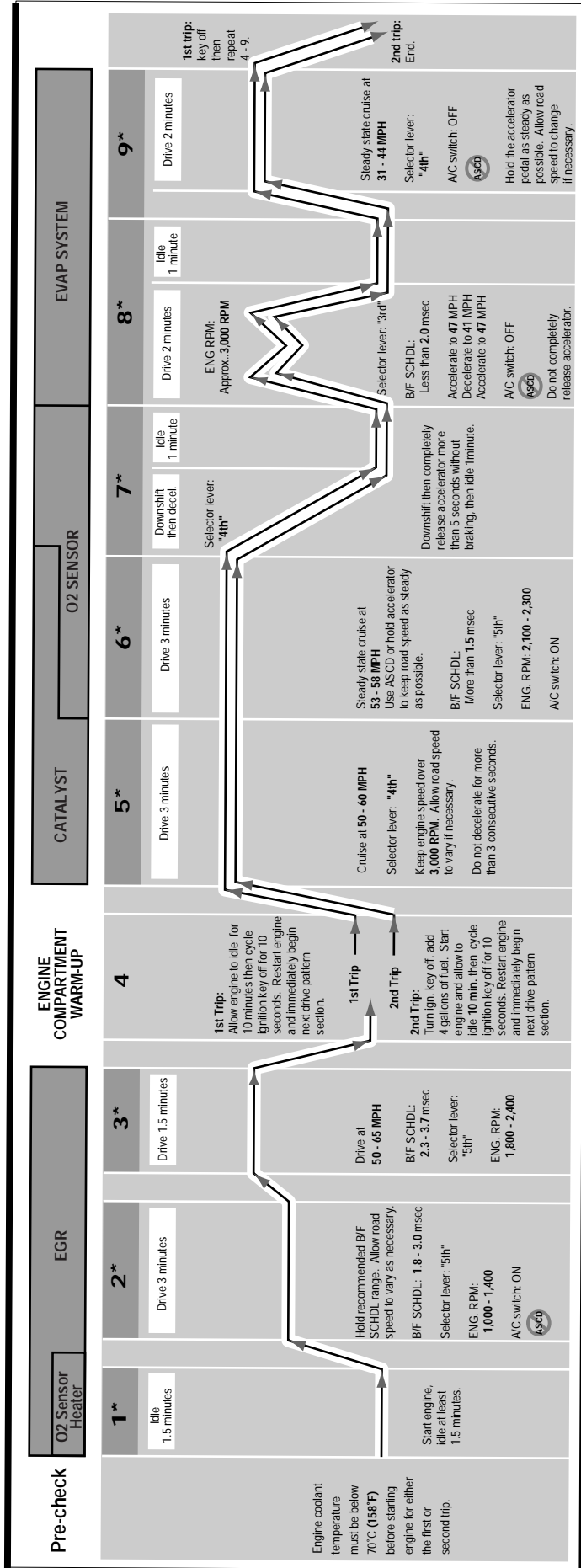

NOTE: It is better to perform this driving test when fuel level is less than 1/2.

If fuel level is greater than 1/2 more time may be required to complete EVAP sections of the drive pattern. Also you may be unable to add fuel as required.

* Dark shading behind section number indicates this drive pattern section must be repeated without turning the ignition off, if it is interrupted by releasing the accelerator when not directed to do so.

System Readiness Test Drive Pattern #12

ECM Part Numbers: 23710-54U10, -54U11, -54U12, -54U13, -54U14, -54U15, -54U16, -56U70, -56U71, -56U72, -56U73, -56U74, -56U76

Two Trip Logic

First Trip: Drive all sections 1 through 9.

Second Trip: Turn ign. off. Add 4 gallons fuel. Start engine and drive sections 4, 5, 6, 7, 8, 9.

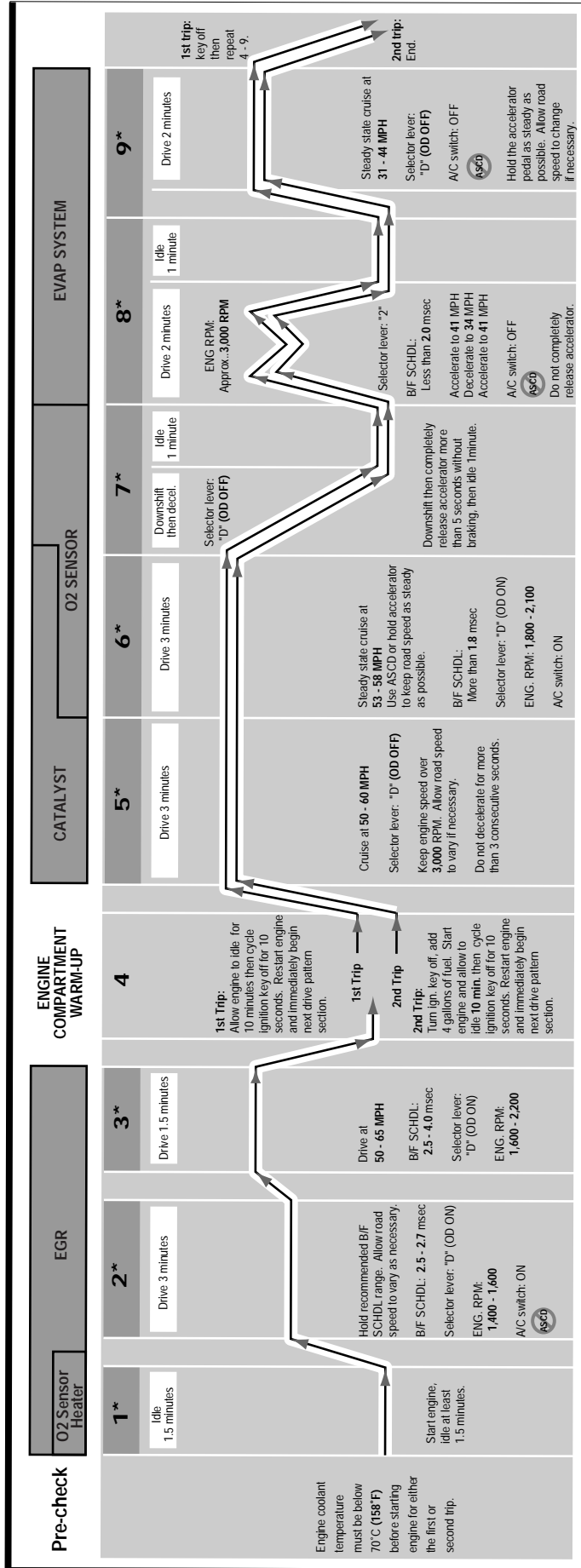

NOTE: It is better to perform this driving test when fuel level is less than 1/2. If fuel level is greater than 1/2 more time may be required to complete EVAP sections of the drive pattern. Also you may be unable to add fuel as required.

* Dark shading behind section number indicates this drive pattern section must be repeated, without turning the ignition off, if it is interrupted by releasing the accelerator when not directed to do so.

'96 Maxima A/T

System Readiness Test Drive Pattern #13

ECM Part Numbers: 23710-0L700, -0L701, -0L702, -0L707, -0L708, -0L709, -0L760, -0L761, -0L762, -0L767, -0L768, -0L769

All Items: Two Trip Logic. Drive all sections two times.

First Trip: Drive all sections 1 through 8 then turn ign. off and allow engine to cool below 70°C. (158°F).

Second Trip: Start engine, drive sections 1,2,3. Turn ign. off and add 4 gallons of fuel in section 4, then start engine and drive sections 5, 6, 7, 8.

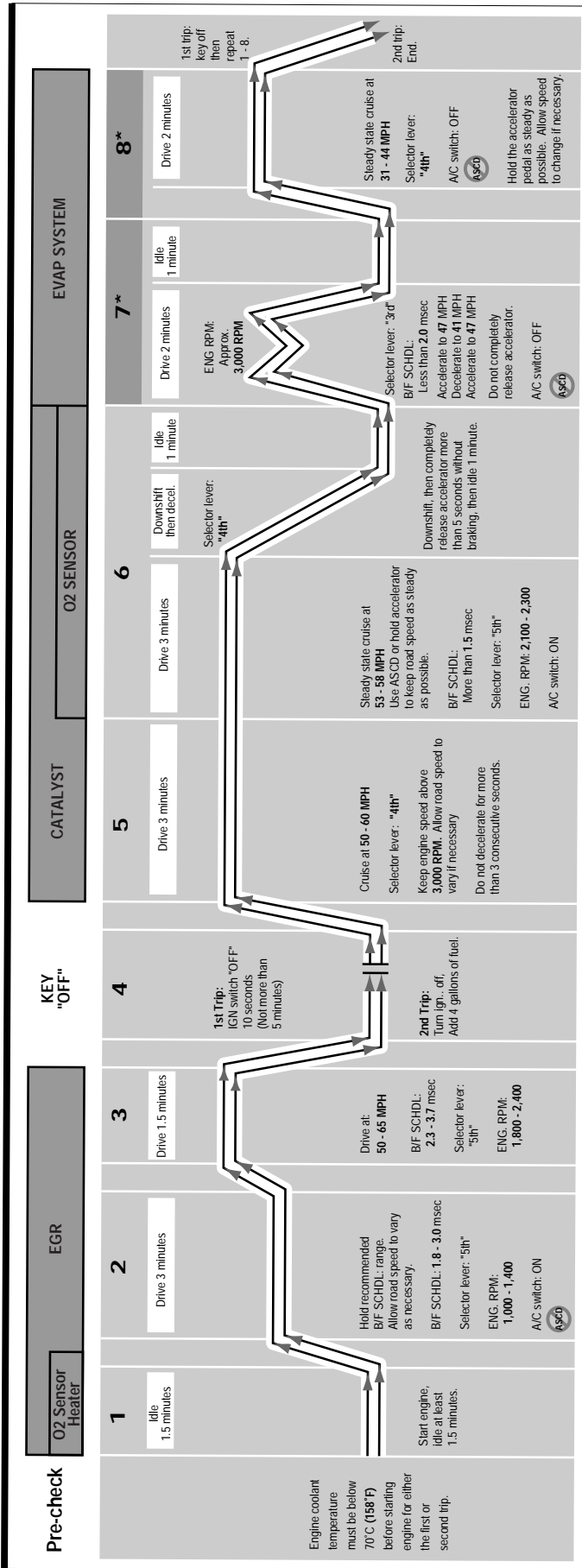

NOTE: It is better to perform this driving test when fuel level is less than 1/2. If fuel level is greater than 1/2 more time may be required to complete EVAP sections of the drive pattern. Also you may be unable to add fuel as required.

* Dark shading behind section number indicates this drive pattern section must be repeated, without turning the ignition off, if it is interrupted by releasing the accelerator when not directed to do so.

'97 Maxima M/T

System Readiness Test Drive Pattern #14

ECM Part Numbers: 23710-0L710, -0L711, -0L712, -0L717, -0L718, -0L719, -0L770, -0L771, -0L772, -0L777, -0L778, -0L779

All Items: Two Trip Logic. Drive all sections two times.

First Trip: Drive all sections 1 through 8 then turn ign. off and allow engine to cool below 70°C. (158°F).

Second Trip: Start engine, drive sections 1,2,3. Turn ign. off and add 4 gallons of fuel in section 4, then start engine and drive sections 5, 6, 7, 8.

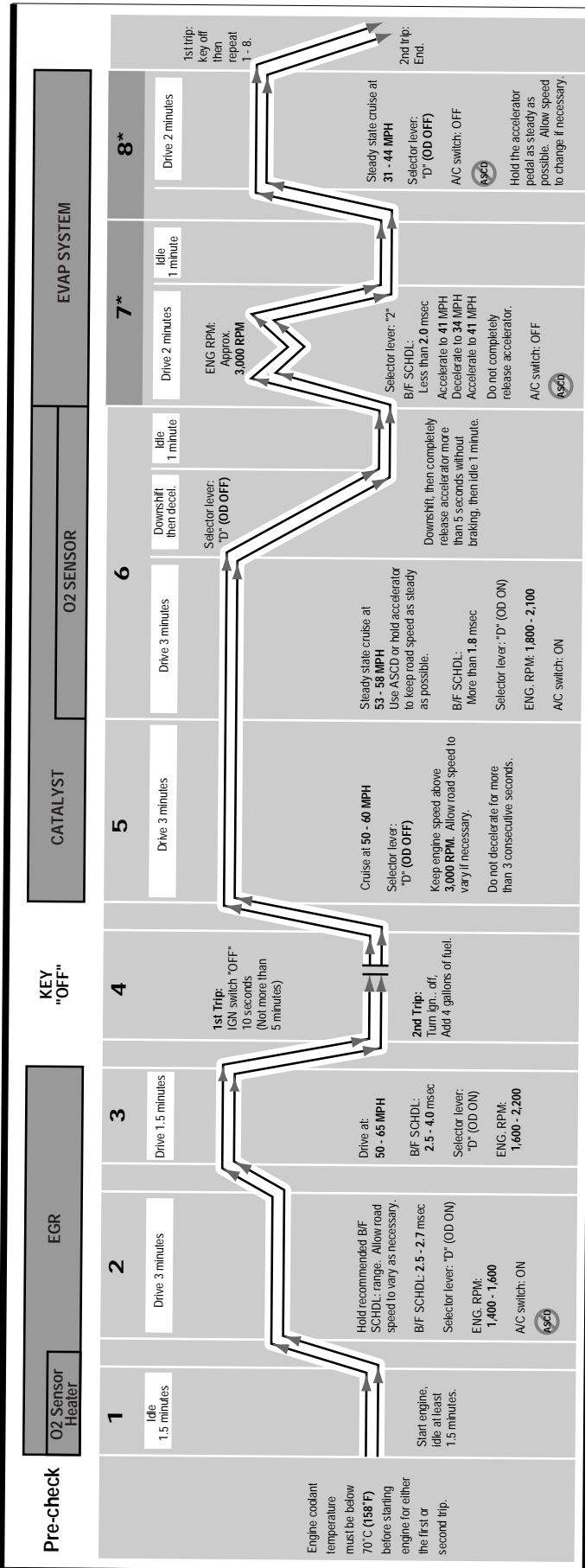

NOTE: It is better to perform this driving test when fuel level is less than 1/2. If fuel level is greater than 1/2 more time may be required to complete EVAP sections of the drive pattern. Also you may be unable to add fuel as required.

* Dark shading behind section number indicates this drive pattern section must be repeated, without turning the ignition off, if it is interrupted by releasing the accelerator when not directed to do so.

System Readiness Test Drive Pattern #15

ECM Part Numbers: 23710-0W000, -0W005, -0W060, -0W061, -0W063

One Trip Logic for all sections.
Drive all sections one time.

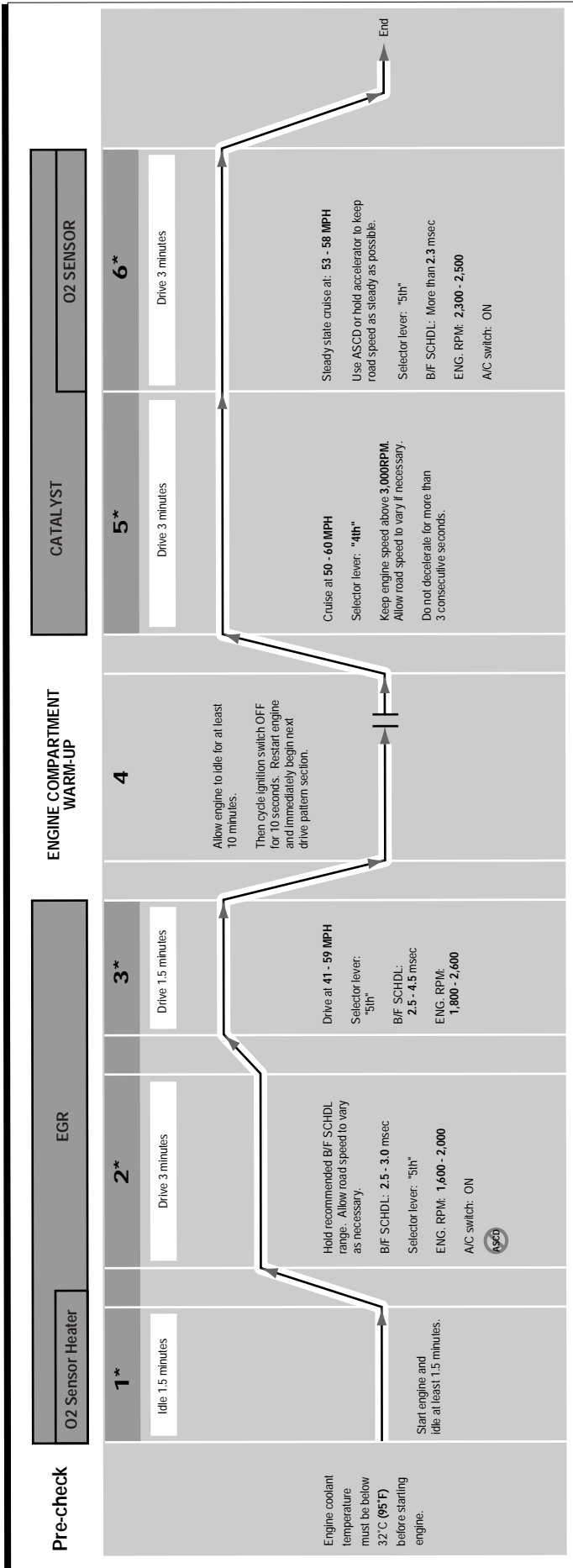

* Dark shading behind section number indicates this drive pattern section must be repeated, without turning the ignition off, if it is interrupted by releasing the accelerator when not directed to do so.

'96 Pathfinder M/T

System Readiness Test Drive Pattern #16

ECM Part Numbers: 23710-0W010, -0W015, -0W065, -0W066, -0W067, -0W069

One Trip Logic for all sections.
Drive all sections one time.

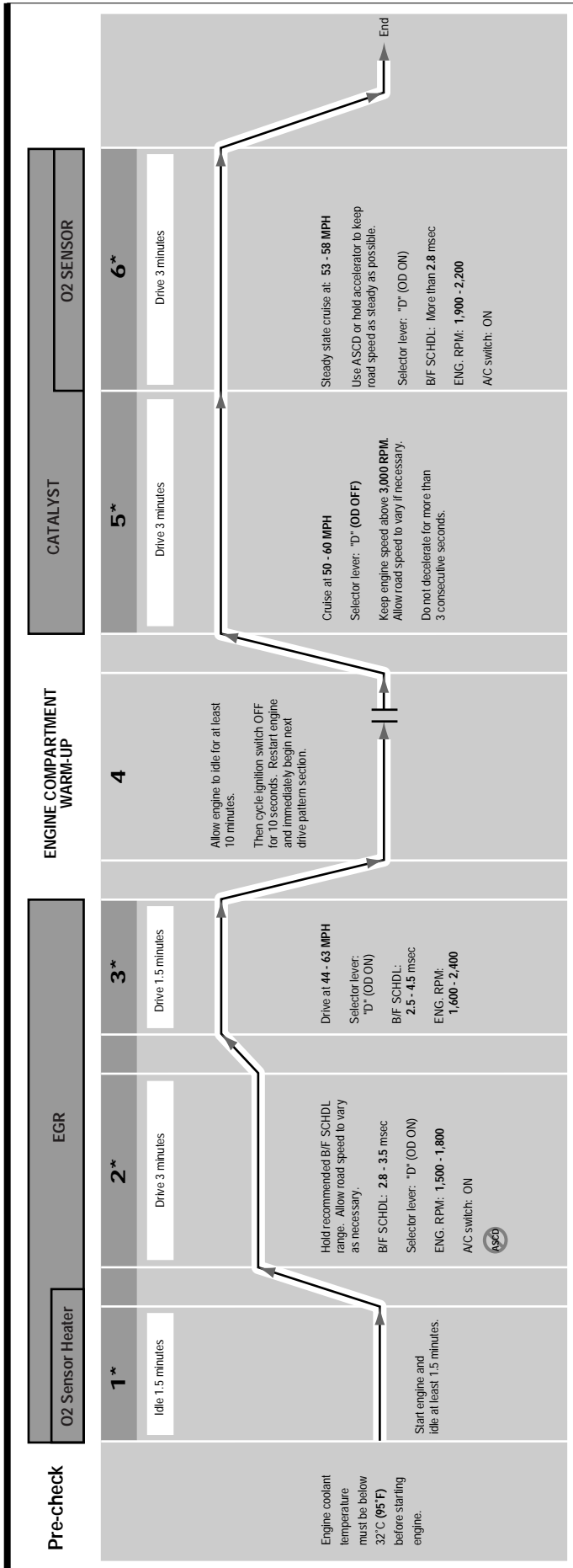

* Dark shading behind section number indicates this drive pattern section must be repeated, without turning the ignition off, if it is interrupted by releasing the accelerator when not directed to do so.

System Readiness Test Drive Pattern #17

ECM Part Numbers: 23710-1W200, -1W201, -1W202, -1W203, -1W204, -1W260, -1W262

All Items: Two Trip Logic. Drive all sections two times.

First Trip: Drive all sections 1 through 8 then turn ign. off and allow engine to cool below 70°C. (158°F).

Second Trip: Start engine, drive sections 1,2,3. Turn ign. off and add 4 gallons of fuel in section 4, then start engine and drive sections 5, 6, 7, 8.

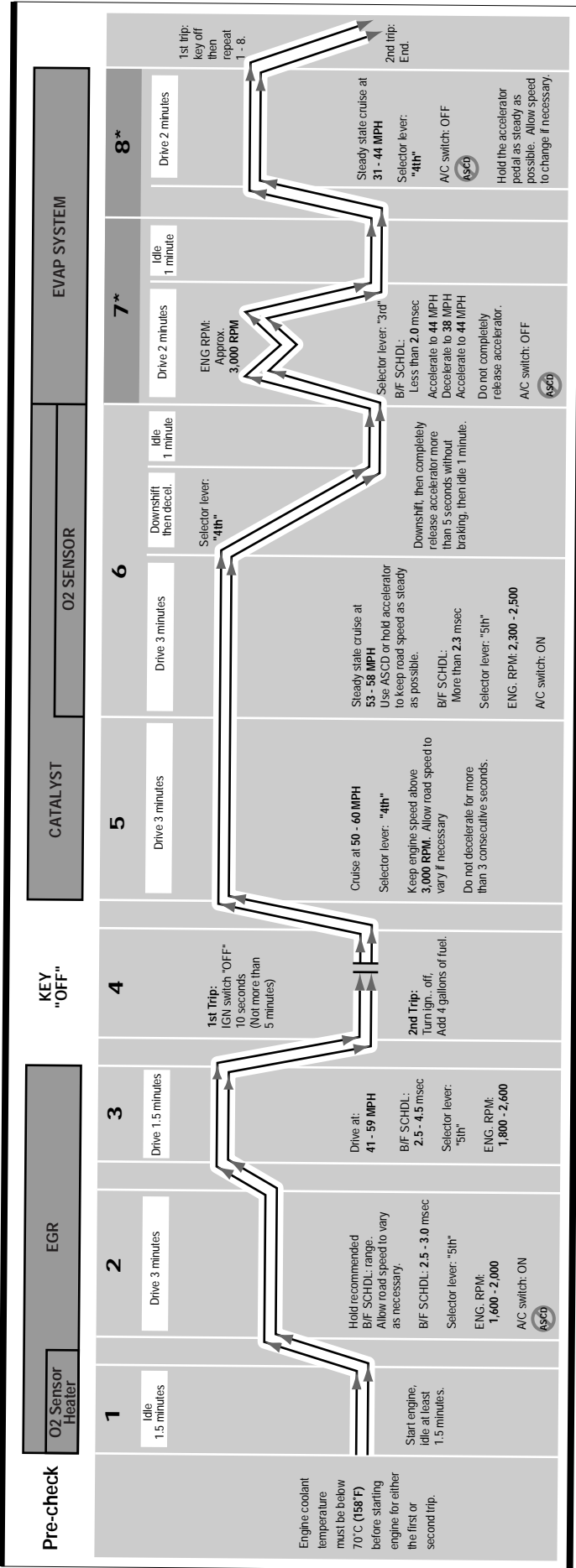

NOTE: It is better to perform this driving test when fuel level is less than 1/2.

If fuel level is greater than 1/2 more time may be required to complete EVAP sections of the drive pattern. Also you may be unable to add fuel as required.

* Dark shading behind section number indicates this drive pattern section must be repeated, without turning the ignition off, if it is interrupted by releasing the accelerator when not directed to do so.

System Readiness Test Drive Pattern #18

ECM Part Numbers: 23710-1W205, -1W206, -1W207, -1W208, -1W209, -1W265, -1W266, -1W268

All Items: Two Trip Logic. Drive all sections two times.

First Trip: Drive all sections 1 through 8 then turn ign. off and allow engine to cool below 70°C. (158°F).

Second Trip: Start engine, drive sections 1,2,3. Turn ign. off and add 4 gallons of fuel in section 4, then start engine and drive sections 5,6,7,8.

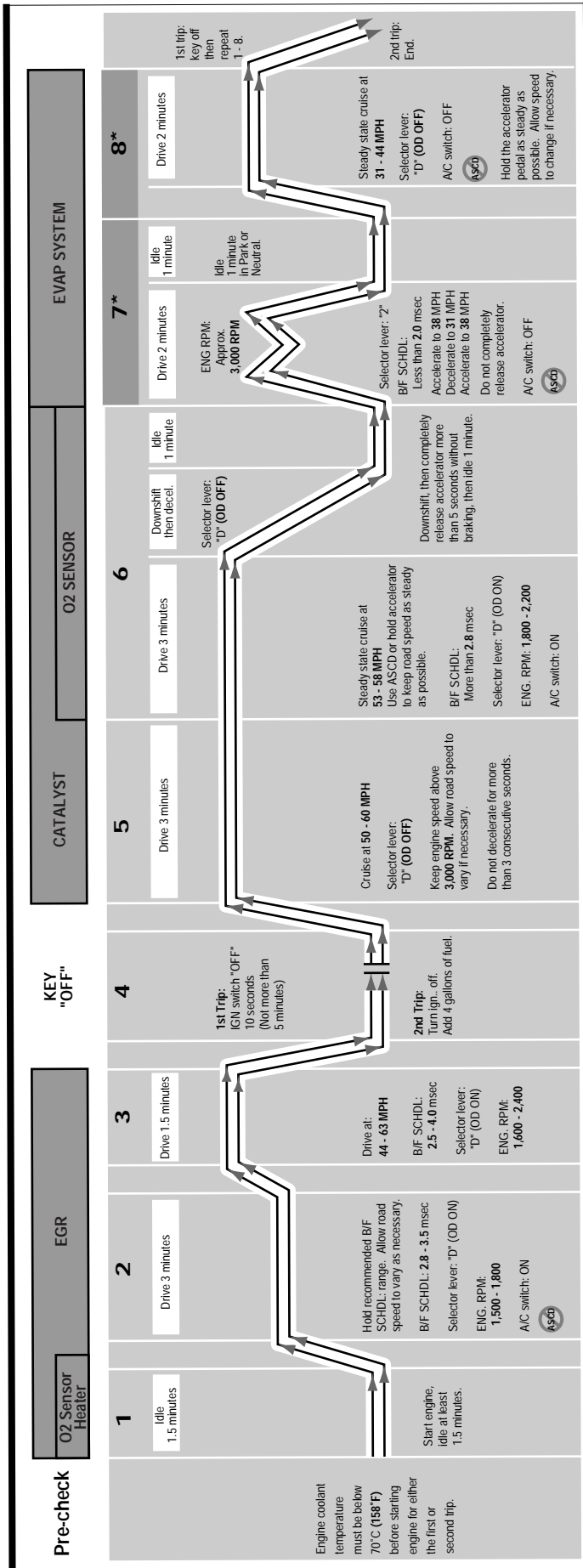

NOTE: It is better to perform this driving test when fuel level is less than 1/2.

If fuel level is greater than 1/2 more time may be required to complete EVAP sections of the drive pattern. Also you may be unable to add fuel as required.

* Dark shading behind section number indicates this drive pattern section must be repeated, without turning the ignition off, if it is interrupted by releasing the accelerator when not directed to do so.

System Readiness Test Drive Pattern #19

ECM Part Numbers: 23710-1B000, -1B001, -1B002

One Trip Logic for all sections.
Drive all sections one time.

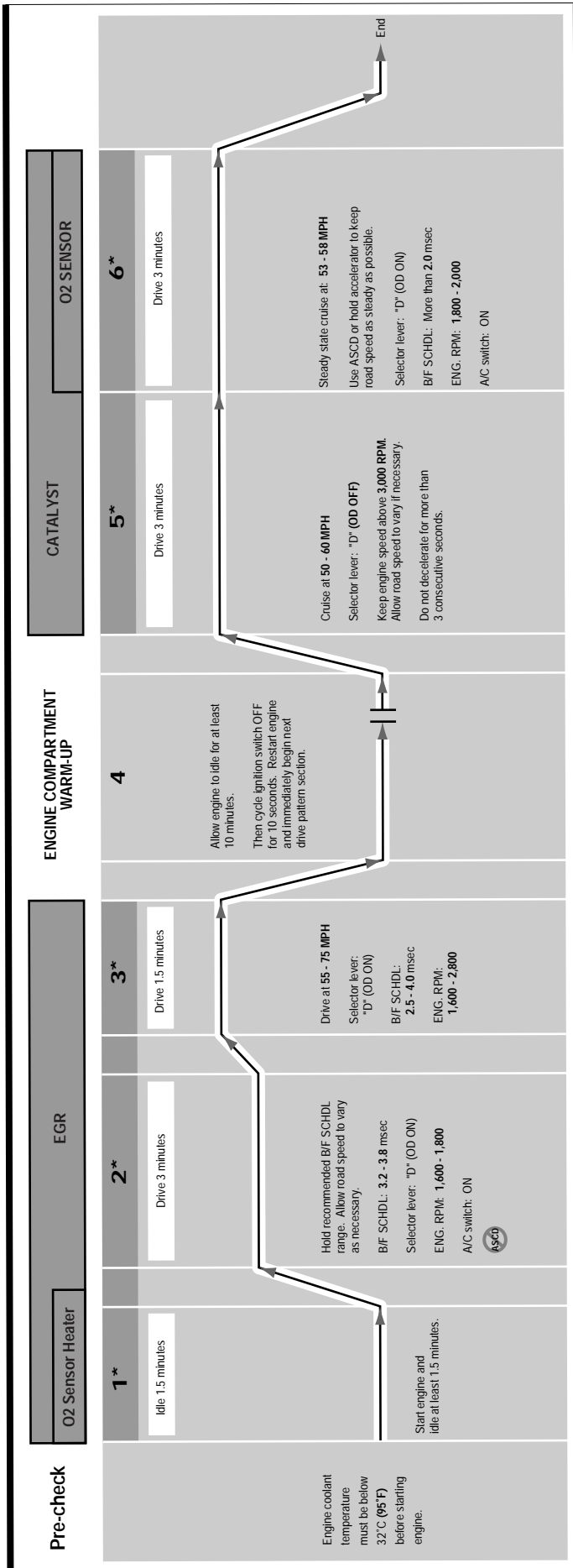

System Readiness Test Drive Pattern #20

ECM Part Numbers: 23710-1B010, -1B011, -1B012, -1B013, -1B014

Two Trip Logic (all sections)

1st Trip: Drive 1 through 6, then turn ign. off and allow engine to cool to 158°F.

2nd Trip: Drive sections 1 through 6 again.

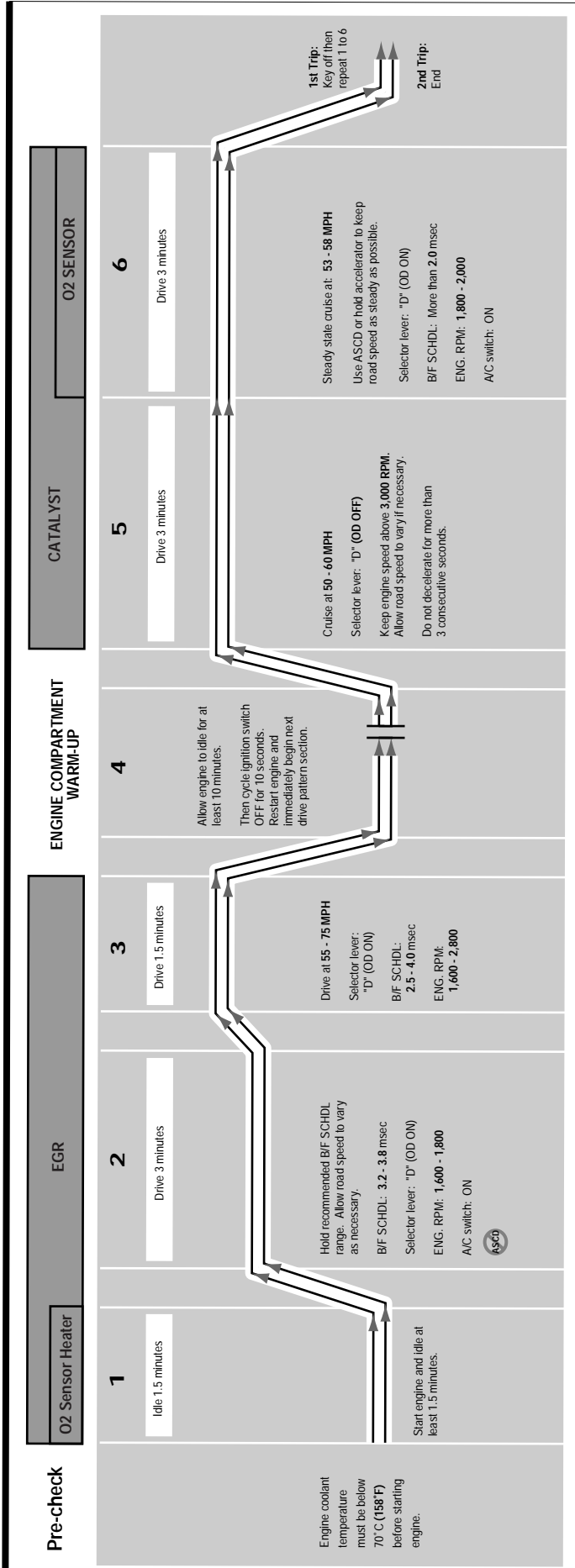

System Readiness Test Drive Pattern #21

ECM Part Numbers: 23710-0M220, -0M221, -0M224, -0M262, -0M263, -0M269, -0M270, -0M271, -0M272, -0M273, -0M274, -1M214, -1M217, 1M222, -1M565, -1M566

One Trip Logic for all sections.
Drive all sections one time.

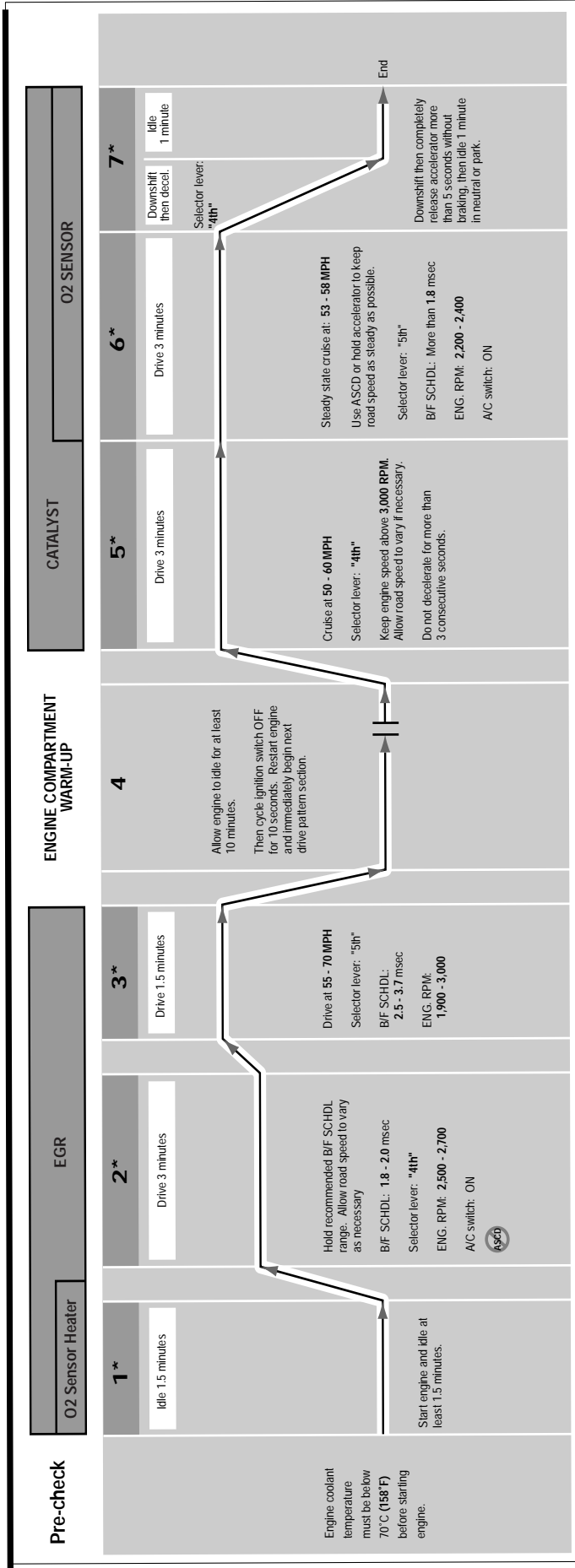

* Dark shading behind section number indicates this drive pattern section must be repeated, without turning the ignition off, if it is interrupted by releasing the accelerator when not directed to do so.

'96 Sentra/200SX (GA16DE) M/T

System Readiness Test Drive Pattern #22

ECM Part Numbers: 23710-0M260, -0M261, -0M264, -0M279, -0M282, -0M283, -1M204, -1M216, -1M221, -1M520, -1M521

One Trip Logic for all sections.
Drive all sections one time.

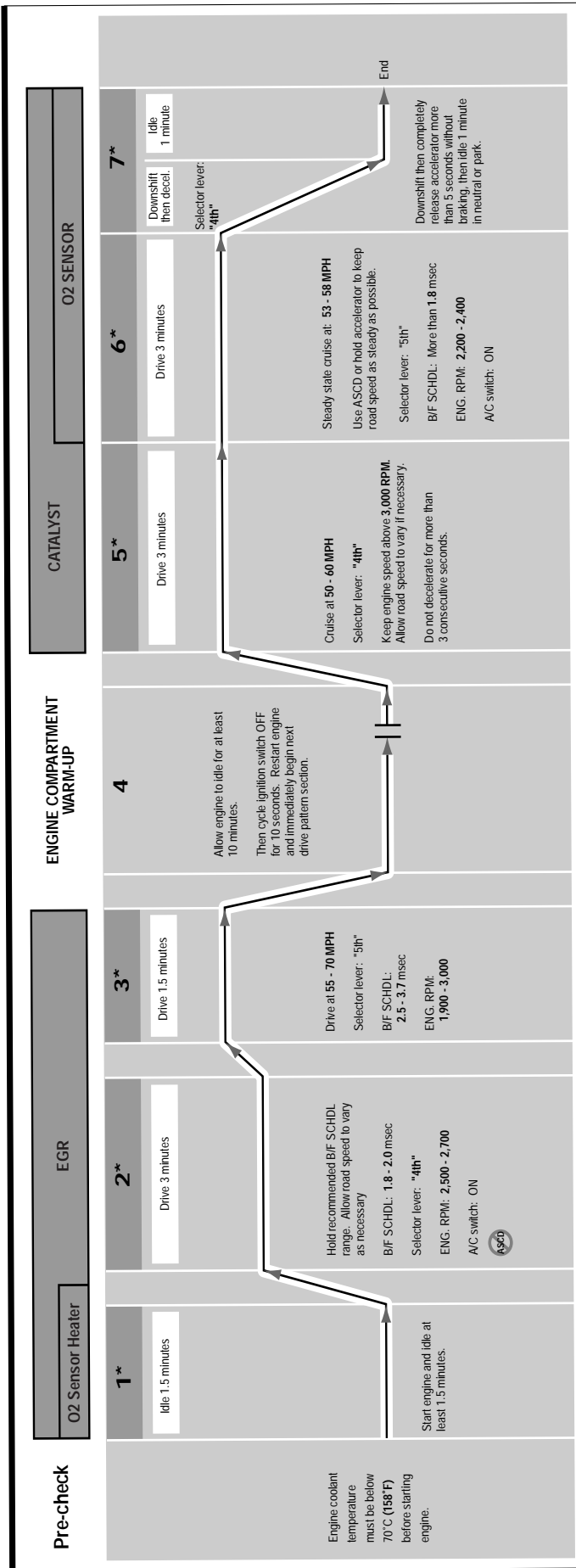

* Dark shading behind section number indicates this drive pattern section must be repeated, without turning the ignition off, if it is interrupted by releasing the accelerator when not directed to do so.

System Readiness Test Drive Pattern #23

ECM Part Numbers: 23710-0M222, -0M223, -0M265, -0M266, -0M267, -0M275, -0M276, -0M277, -0M278, -0M280, -0M284, -1M219, -1M223, -1M275, -1M575, -1M576, -1M580, -1M581

One Trip Logic for all sections.
Drive all sections one time.

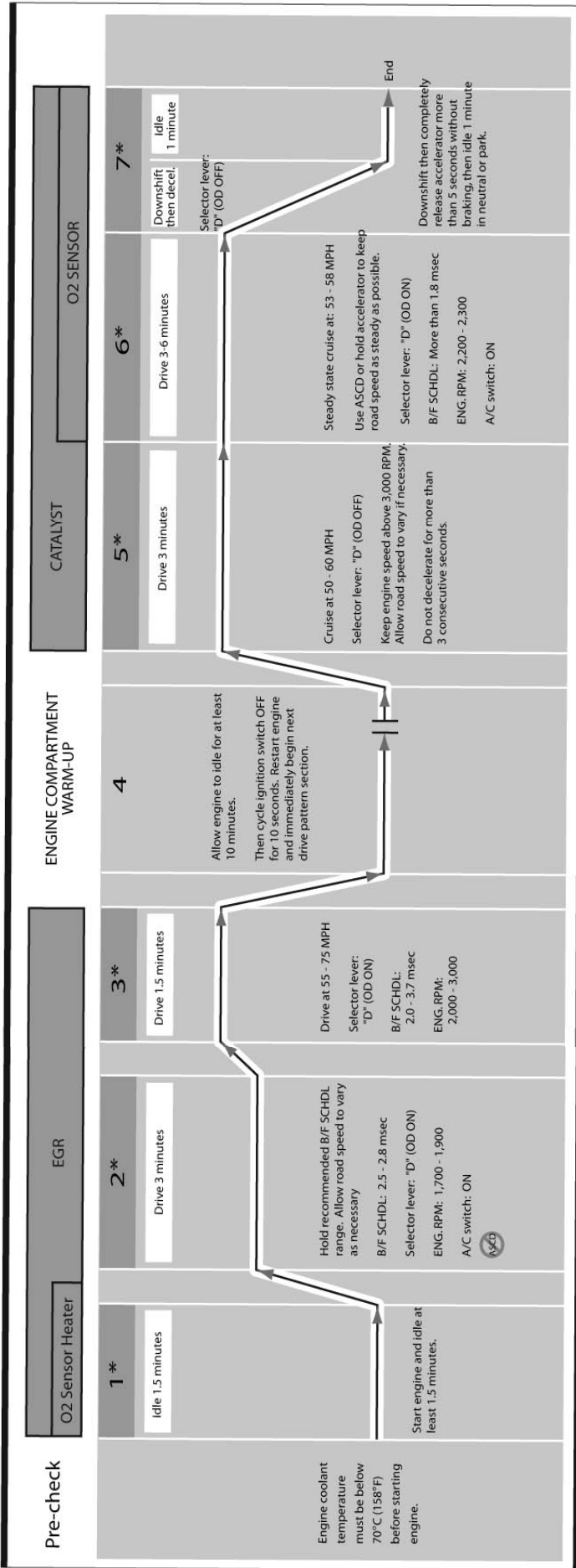

* Dark shading behind section number indicates this drive pattern section must be repeated, without turning the ignition off, if it is interrupted by releasing the accelerator when not directed to do so.

'96 Sentra/200SX (GA16DE) A/T

System Readiness Test Drive Pattern #24

ECM Part Numbers: 23710-3M200, -3M202, -3M203, -3M204, -3M205, -3M206, -3M207, -3M208, -3M209, -3M260, -3M261, -3M270, -3M271, -3M300, -3M302, -3M303, -3M304, -3M305, -3M306, -3M307, -3M308, -3M309, -3M360, -3M361, -3M370, -3M371

All Items: Two Trip Logic. Drive all sections two times.

First Trip: Drive all sections 1 through 8 then turn ign. off and allow engine to cool below 70°C. (158°F).

Second Trip: Start engine, drive sections 1,2,3. Turn ign. off and add 4 gallons of fuel in section 4, then start engine and drive sections 5, 6, 7, 8.

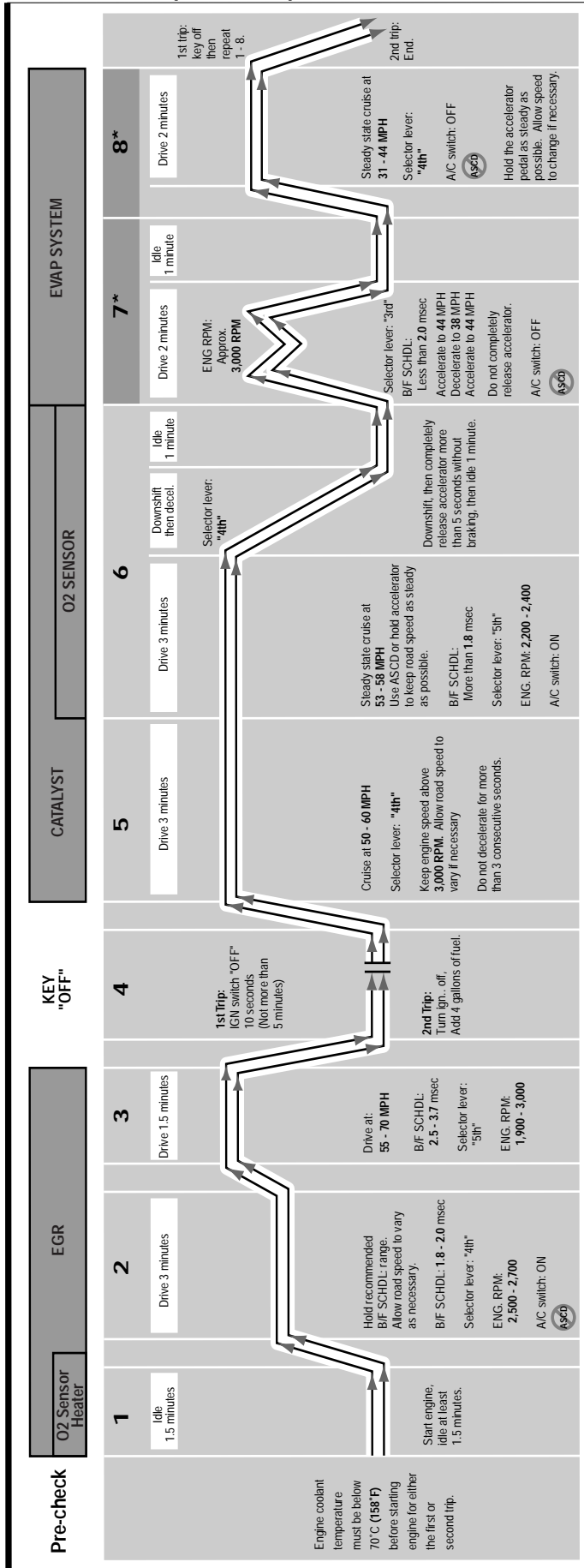

NOTE: It is better to perform this driving test when fuel level is less than 1/2.

If fuel level is greater than 1/2 more time may be required to complete EVAP sections of the drive pattern. Also you may be unable to add fuel as required.

* Dark shading behind section number indicates this drive pattern section must be repeated, without turning the ignition off, if it is interrupted by releasing the accelerator when not directed to do so.

'97 Sentra/200SX (GA16DE) M/T

System Readiness Test Drive Pattern #25

ECM Part Numbers: 23710-3M210, -3M212, -3M213, -3M214, -3M215, -3M216, -3M217, -3M218, -3M219, -3M265, -3M266, -3M275, -3M276, -3M310, -3M312, -3M313, -3M314, -3M315, -3M316, -3M317, -3M318, -3M319, -3M365, -3M366, -3M375, -3M376

All Items: Two Trip Logic. Drive all sections two times.

First Trip: Drive all sections 1 through 8 then turn ign. off and allow engine to cool below 70°C. (158°F).

Second Trip: Start engine; drive sections 1,2,3. Turn ign. off and add 4 gallons of fuel in section 4, then start engine and drive sections 5, 6, 7, 8.

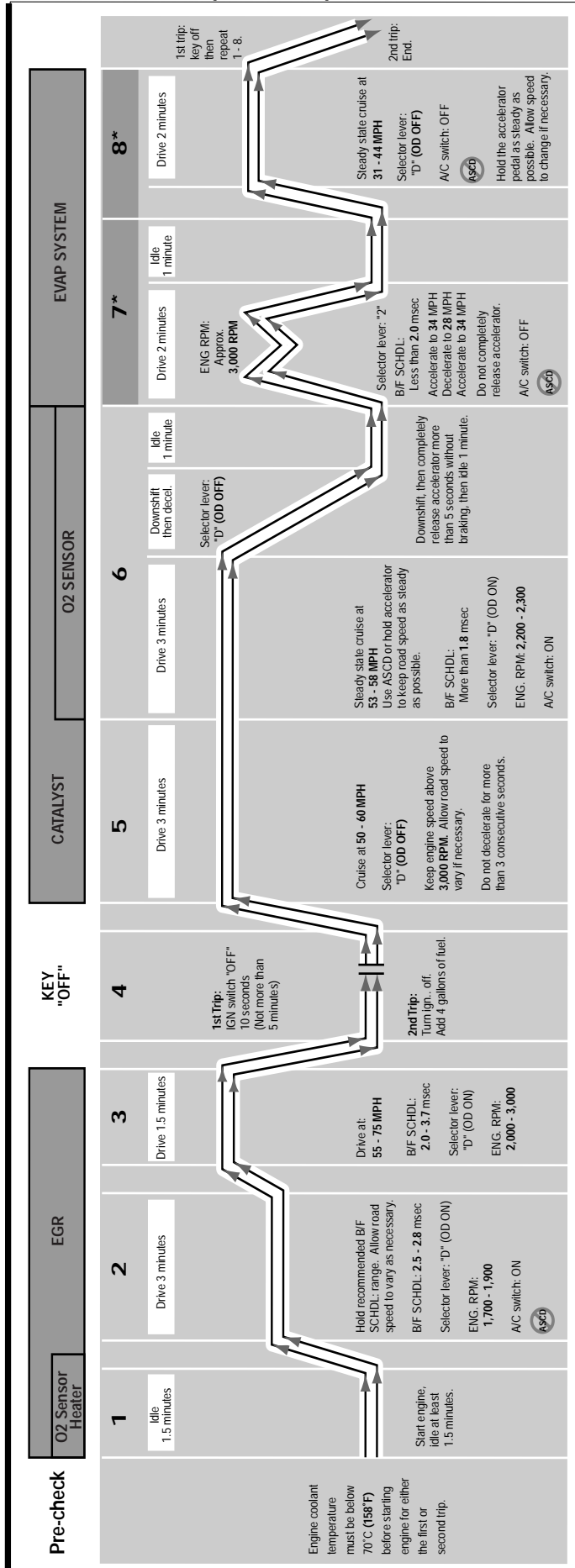

NOTE: It is better to perform this driving test when fuel level is less than 1/2. If fuel level is greater than 1/2 more time may be required to complete EVAP sections of the drive pattern. Also you may be unable to add fuel as required.

* Dark shading behind section number indicates this drive pattern section must be repeated, without turning the ignition off, if it is interrupted by releasing the accelerator when not directed to do so.

'97 Sentra/200SX (GA16DE) A/T

System Readiness Test Drive Pattern #26

ECM Part Numbers: 23710-1M860, 1M861, -1M870, -1M871, -1M872

One Trip Logic for all sections.
Drive all sections one time.

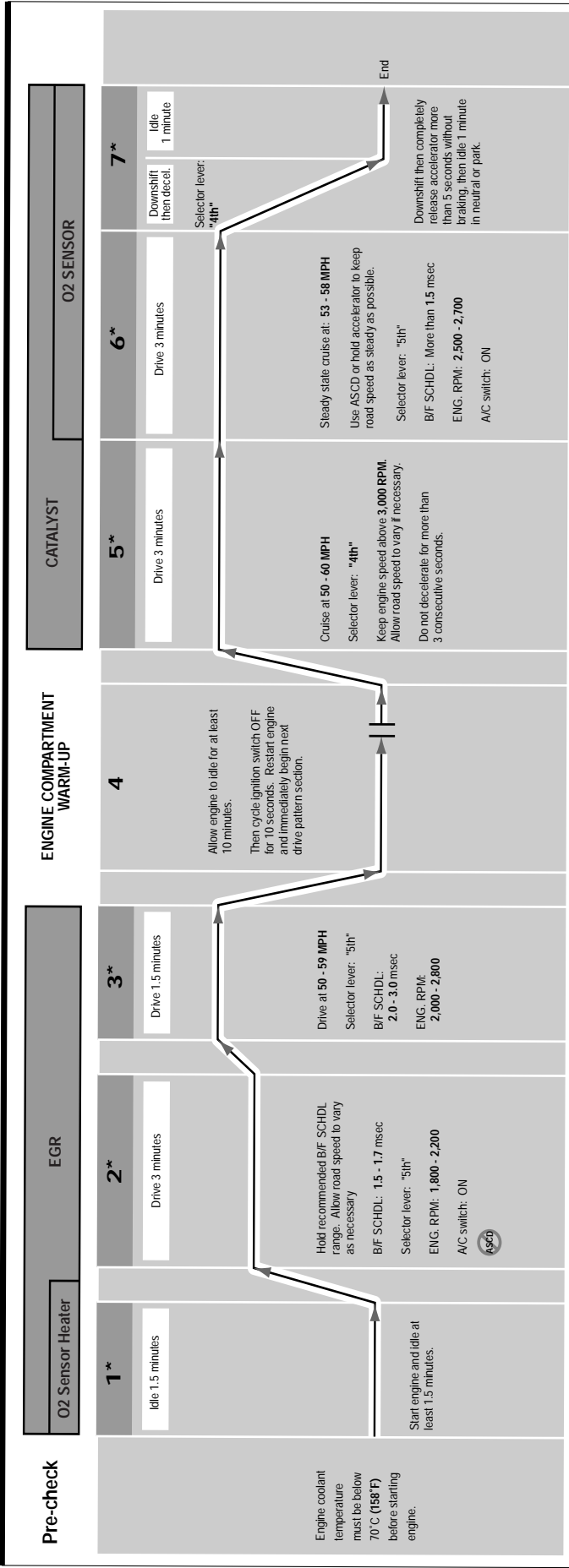

* Dark shading behind section number indicates this drive pattern section must be repeated, without turning the ignition off, if it is interrupted by releasing the accelerator when not directed to do so.

'96-'97 200SX (SR20DE) M/T

System Readiness Test Drive Pattern #27

ECM Part Numbers: 23710-1M865, -1M866, -1M875, -1M876, -1M877

One Trip Logic for all sections.
Drive all sections one time.

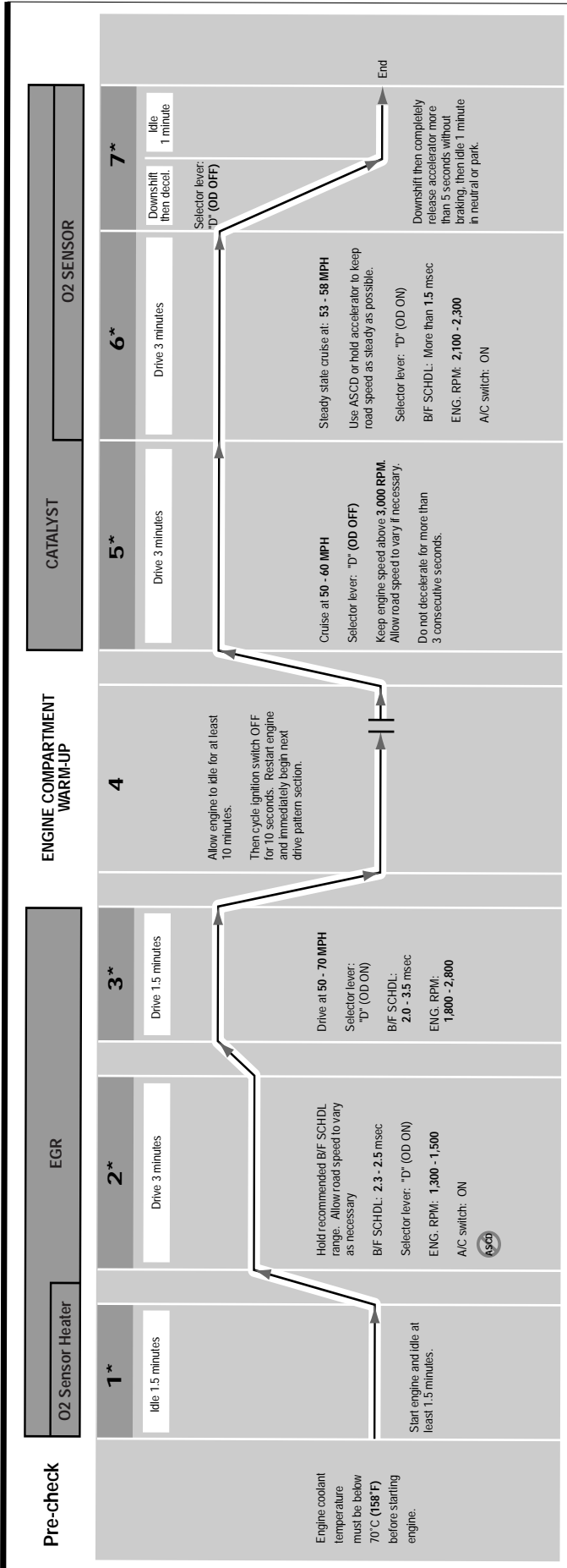

System Readiness Test Drive Pattern #28

ECM Part Numbers: 23710-1S700, -1S701, -1S702, -1S703

One Trip Logic for all sections.
Drive all section one time.

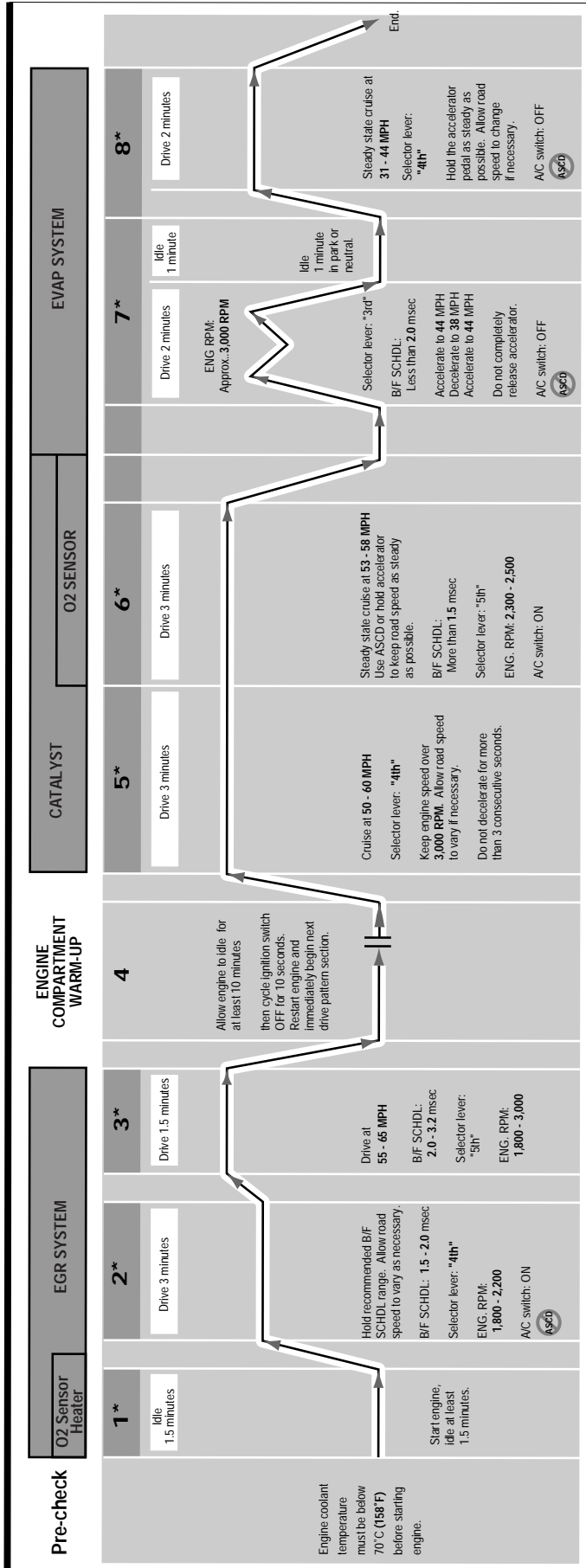

NOTE: It is better to perform this driving test when fuel level is less than 1/2. If fuel level is greater than 1/2 more time may be required to complete EVAP sections of the drive pattern.

* Dark shading behind section number indicates this drive pattern section must be repeated, without turning the ignition off, if it is interrupted by releasing the accelerator when not directed to do so.

System Readiness Test Drive Pattern #29

ECM Part Numbers: 23710-1S300, -1S301, -1S306, -1S307, -1S704, -1S706, -1S708, -1S709, -1S717, -1S718, -1S719, -1S720, -1S721, -1S722, -1S723, -1S724

All Items: Two Trip Logic. Drive all sections two times.

First Trip: Drive all sections 1 through 8 then turn ign. off and allow engine to cool below 70°C. (158°F).

Second Trip: Start engine, drive sections 1,2,3. Turn ign. off and add 4 gallons of fuel in section 4, then start engine and drive sections 5, 6, 7, 8.

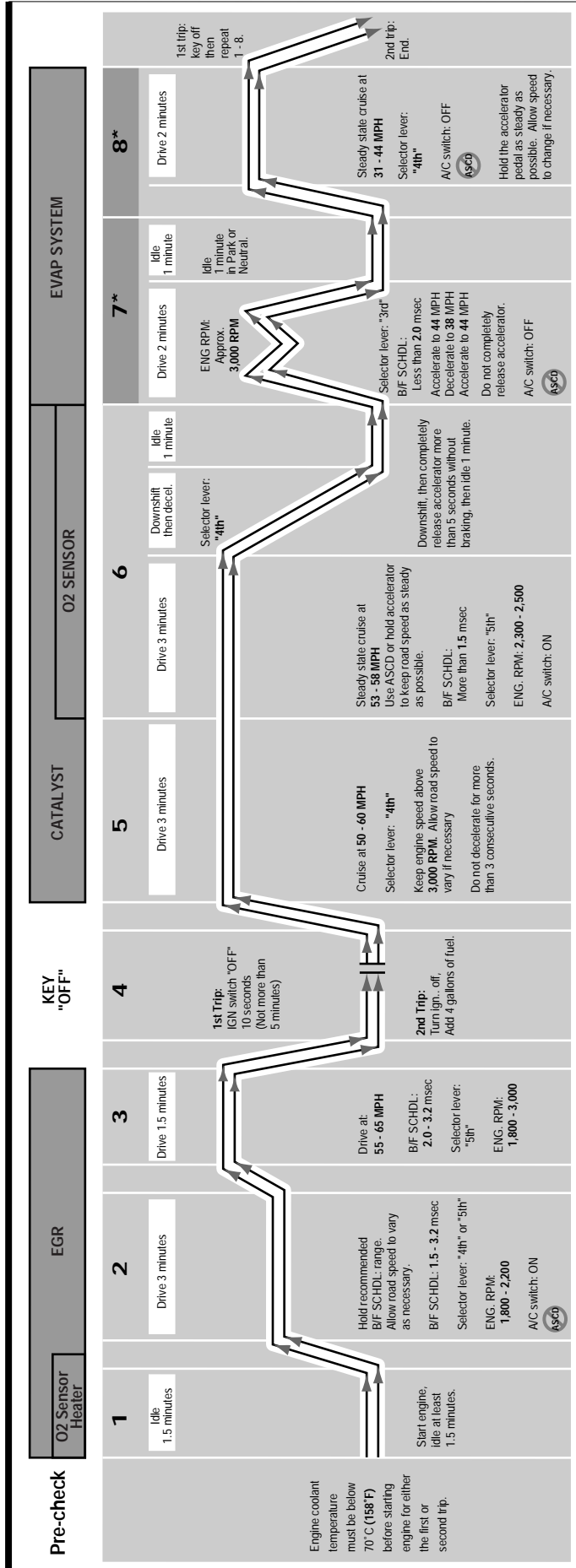

NOTE: It is better to perform this driving test when fuel level is less than 1/2.

If fuel level is greater than 1/2 more time may be required to complete EVAP sections of the drive pattern. Also you may be unable to add fuel as required.

* Dark shading behind section number indicates this drive pattern section must be repeated, without turning the ignition off, if it is interrupted by releasing the accelerator when not directed to do so.

'96 Truck (2WD) M/T

System Readiness Test Drive Pattern #30

ECM Part Numbers: 23710-1S710, -1S712

One Trip Logic for all sections.
Drive all section one time.

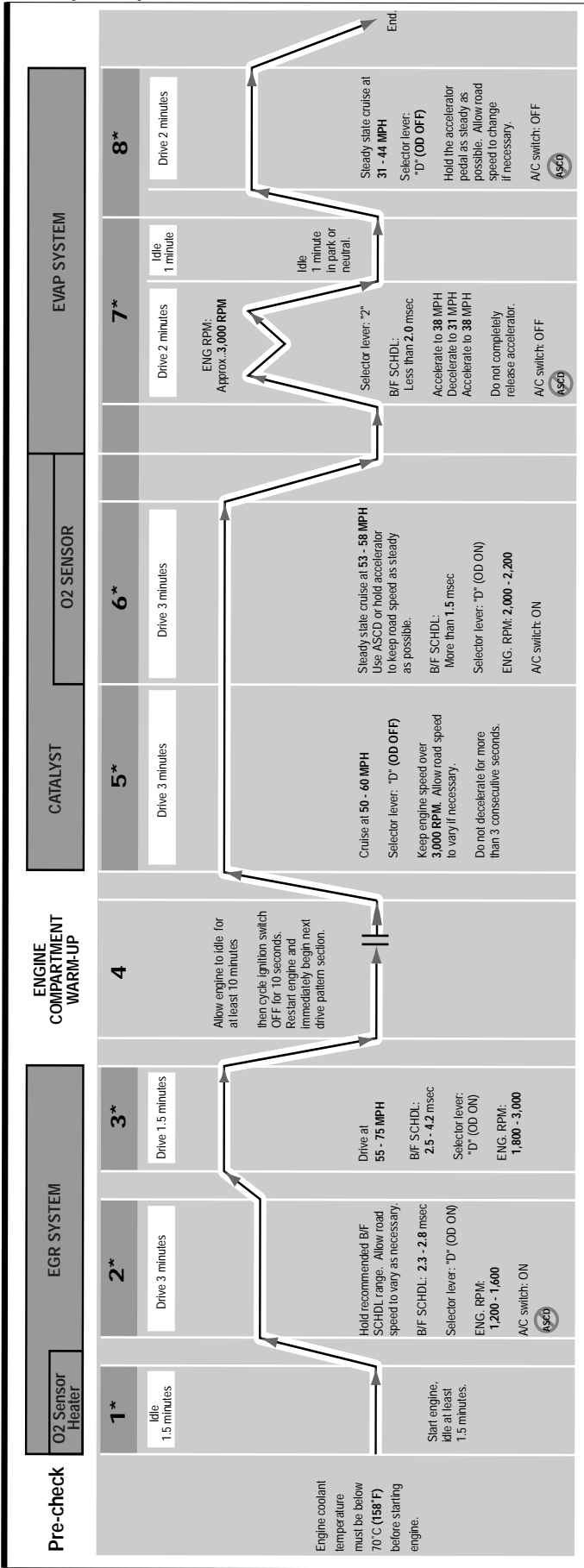

NOTE: It is better to perform this driving test when fuel level is less than 1/2. If fuel level is greater than 1/2 more time may be required to complete EVAP sections of the drive pattern.

* Dark shading behind section number indicates this drive pattern section must be repeated, without turning the ignition off, if it is interrupted by releasing the accelerator when not directed to do so.

System Readiness Test Drive Pattern #31

ECM Part Numbers: 23710-1S302, -1S303, -1S308, -1S713, -1S714, -1S716, -1S768, -1S770, -1S771, -1S772, -1S781, -1S782

All Items: Two Trip Logic. Drive all sections two times.

First Trip: Drive all sections 1 through 8 then turn ign. off and allow engine to cool below 70°C. (158°F).

Second Trip: Start engine, drive sections 1,2,3. Turn ign. off and add 4 gallons of fuel in section 4, then start engine and drive sections 5, 6, 7, 8.

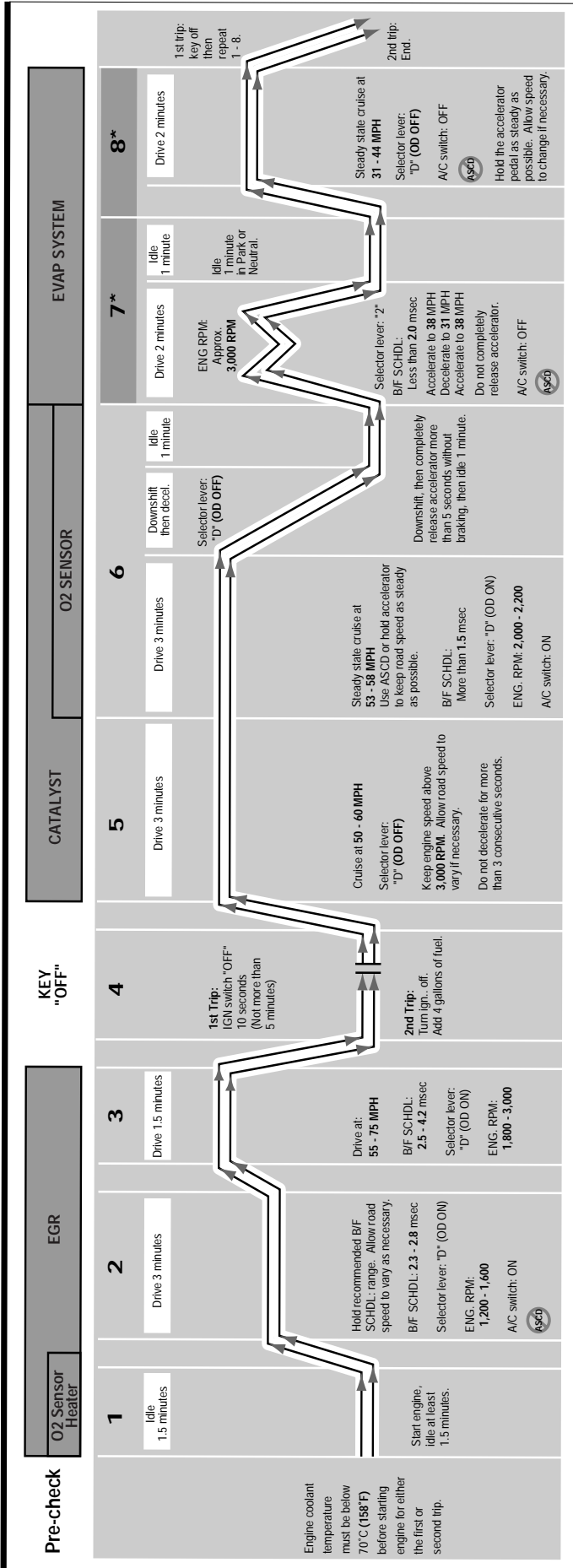

NOTE: It is better to perform this driving test when fuel level is less than 1/2.

If fuel level is greater than 1/2 more time may be required to complete EVAP sections of the drive pattern. Also you may be unable to add fuel as required.

* Dark shading behind section number indicates this drive pattern section must be repeated, without turning the ignition off, if it is interrupted by releasing the accelerator when not directed to do so.

'96 Truck (2WD) A/T

System Readiness Test Drive Pattern #32

ECM Part Numbers: 23710-1S300, -1S301, -1S306, -1S307, -1S704, -1S706, -1S708, -1S709, -1S717, -1S718, -1S719, -1S720, -1S721, -1S722, -1S723, 1S724

All Items: Two Trip Logic. Drive all sections two times.

First Trip: Drive all sections 1 through 8 then turn ign. off and allow engine to cool below 70°C. (158°F)

Second Trip: Start engine, drive sections 1,2,3. Turn ign. off and add 4 gallons of fuel in section 4, then start engine and drive sections 5, 6, 7, 8.

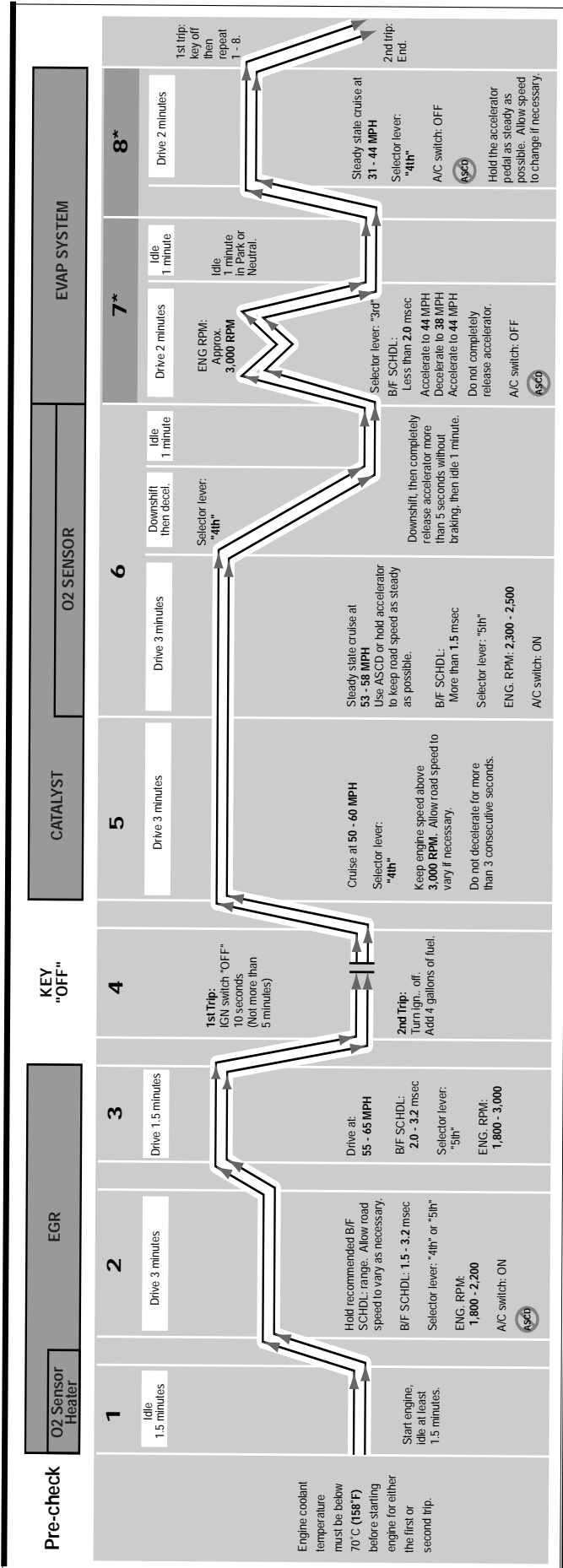

NOTE: It is better to perform this driving test when fuel level is less than 1/2.
If fuel level is greater than 1/2 more time may be required to complete EVAP sections of the drive pattern. Also you may be unable to add fuel as required.

Dark shading behind section number indicates this drive pattern section must be repeated, without turning the ignition off, if it is interrupted by releasing the accelerator when not directed to do so.

System Readiness Test Drive Pattern #33

ECM Part Numbers: 23710-1S302, -1S303, -1S308, -1S710, -1S712, -1S713, -1S714, -1S716, -1S768, -1S770, -1S771, -1S772, -1S781, -1S782

All Items: Two Trip Logic. Drive all sections two times.

First Trip: Drive all sections 1 through 8 then turn ign. off and allow engine to cool below 70 C. (158 F).

Second trip: Start engine, drive sections 1,2,3. Turn ign. off and add 4 gallons of fuel in section 4, then start engine and drive sections 5, 6, 7, 8.

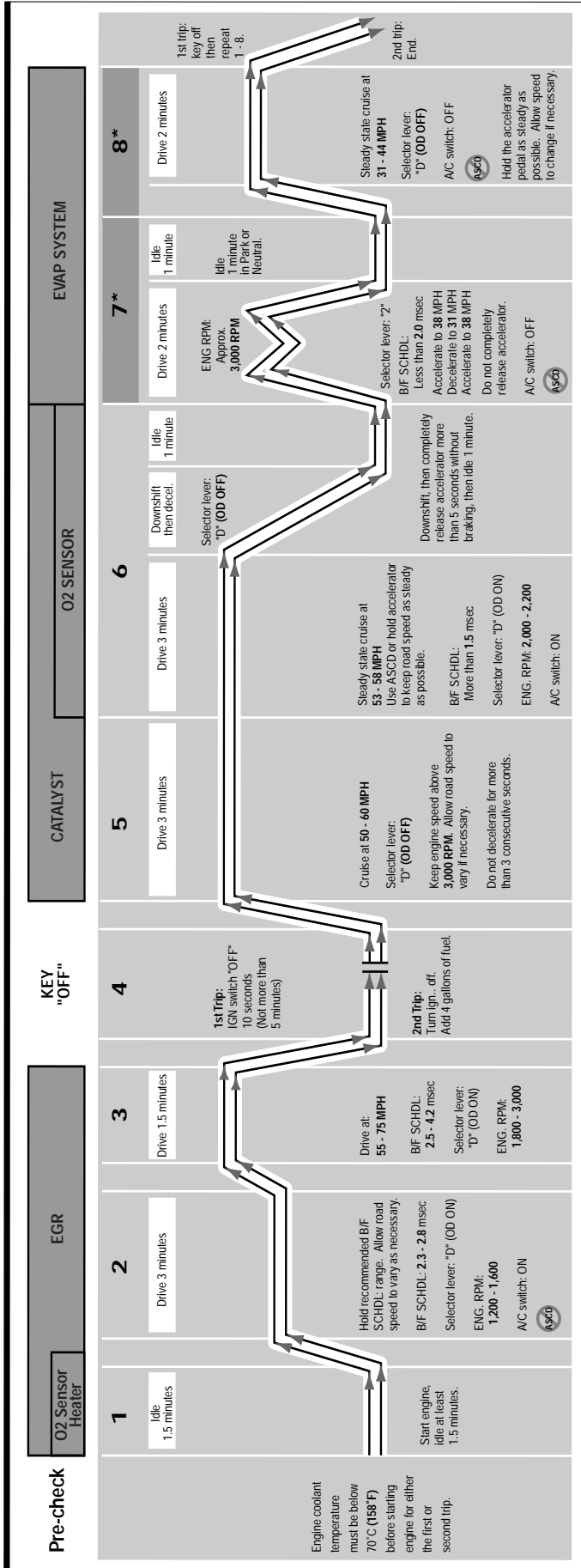

NOTE: It is better to perform this driving test when fuel level is less than 1/2. If fuel level is greater than 1/2 more time may be required to complete EVAP sections of the drive pattern. Also you may be unable to add fuel as required.

* Dark shading behind section number indicates this drive pattern section must be repeated, without turning the ignition off, if it is interrupted by releasing the accelerator when not directed to do so.

System Readiness Test Drive Pattern #34

ECM Part Numbers: 23710-1S760, -1S761, -1S762, -1S763

One Trip Logic for all sections.
Drive all section one time.

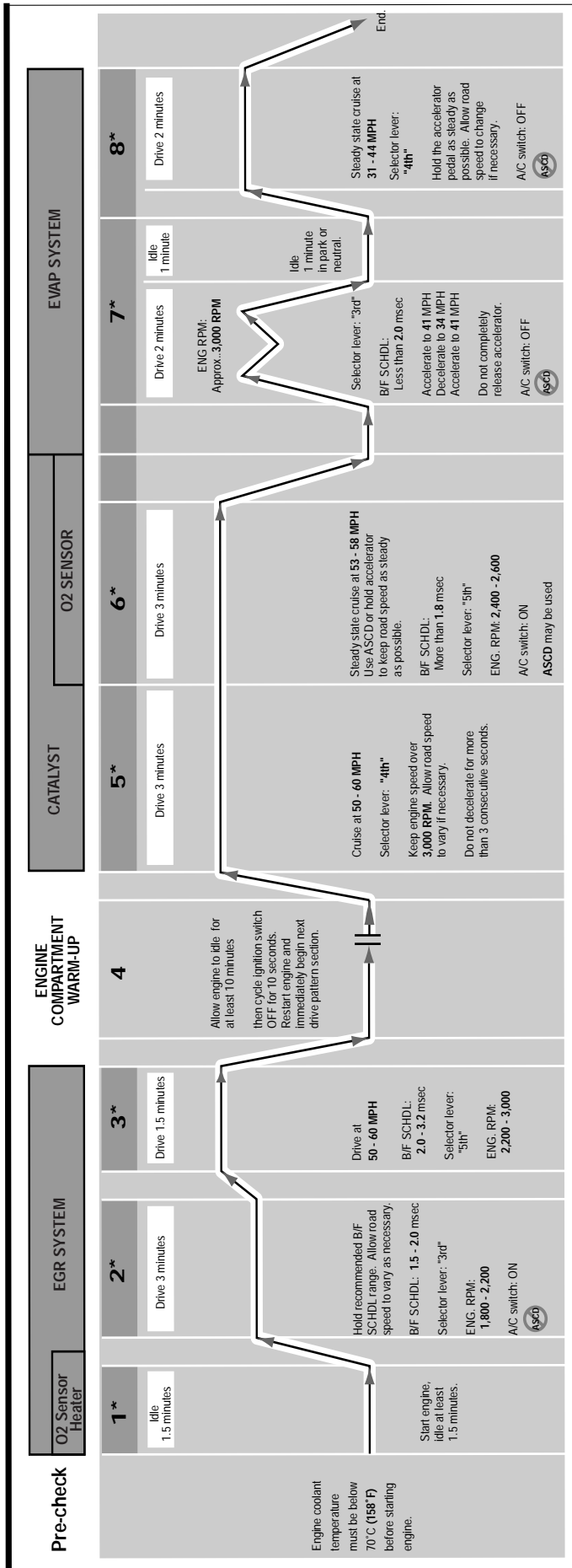

NOTE: It is better to perform this driving test when fuel level is less than 1/2.

If fuel level is greater than 1/2 more time may be required to complete EVAP sections of the drive pattern.

* Dark shading behind section number indicates this drive pattern section must be repeated, without turning the ignition off, if it is interrupted by releasing the accelerator when not directed to do so.

System Readiness Test Drive Pattern #35

ECM Part Numbers: 23710-1S304, -1S305, -1S309, -1S310, -1S764, -1S766, -1S769, -1S774, -1S775, -1S776, -1S777, -1S778, -1S779, -1S780, -1S783, -1S784

All Items: Two Trip Logic. Drive all sections two times.

First Trip: Drive all sections 1 through 8 then turn ign. off and allow engine to cool below 70°C. (158°F).

Second Trip: Start engine, drive sections 1,2,3. Turn ign. off and add 4 gallons of fuel in section 4, then start engine and drive sections 5, 6, 7, 8.

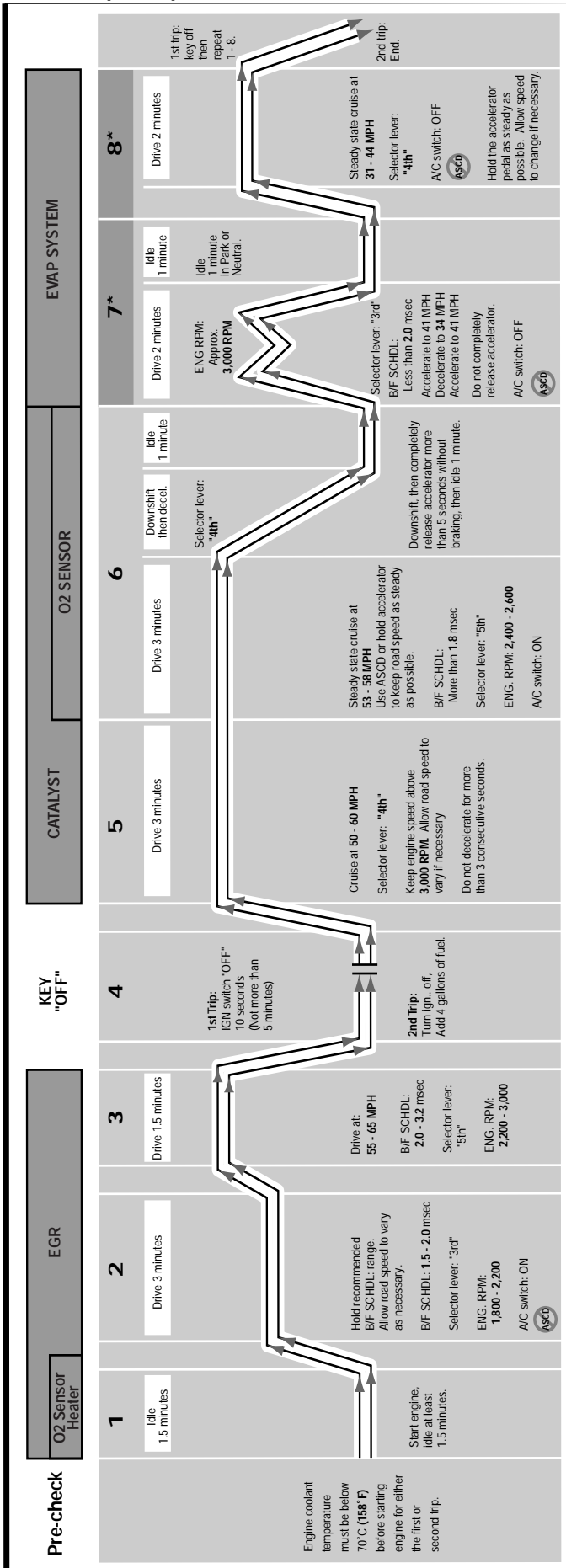

NOTE: It is better to perform this driving test when fuel level is less than 1/2. If fuel level is greater than 1/2 more time may be required to complete EVAP sections of the drive pattern. Also you may be unable to add fuel as required.

* Dark shading behind section number indicates this drive pattern section must be repeated, without turning the ignition off, if it is interrupted by releasing the accelerator when not directed to do so.

'96 Truck (4WD) M/T

System Readiness Test Drive Pattern #36

ECM Part Numbers: 23710-1S304, -1S305, -1S309, -1S310, -1S764, -1S766, -1S769, -1S774, -1S775, -1S776, -1S777, -1S778, -1S779, -1S780, -1S783, -1S784

All Items: Two Trip Logic. Drive all sections two times.

First Trip: Drive all sections 1 through 8 then turn ign. off and allow engine to cool below 70°C. (158°F).

Second Trip: Start engine, drive sections 1,2,3. Turn ign. off and add 4 gallons of fuel in section 4, then start engine and drive sections 5, 6, 7, 8.

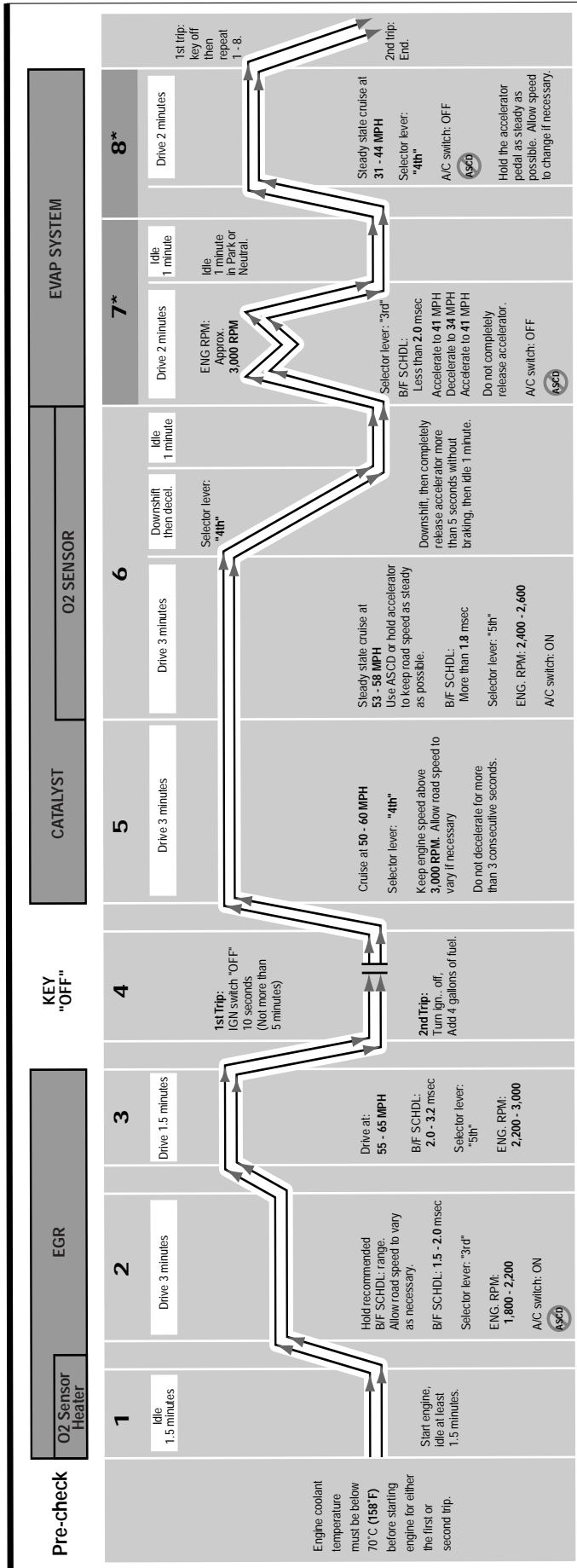

NOTE: It is better to perform this driving test when fuel level is less than 1/2. If fuel level is greater than 1/2 more time may be required to complete EVAP sections of the drive pattern. Also you may be unable to add fuel as required.

* Dark shading behind section number indicates this drive pattern section must be repeated, without turning the ignition off, if it is interrupted by releasing the accelerator when not directed to do so.

System Readiness Test Drive Pattern #37

ECM Part Numbers: 23710-72F00, -72F01, -72F02, -72F03, -72F04, -72F05

Two Trip Logic

First Trip: Drive all sections 1 through 9.

Second Trip: Turn ign. off. Add 4 gallons fuel. Start engine and drive sections 4, 5, 6, 7, 8, 9.

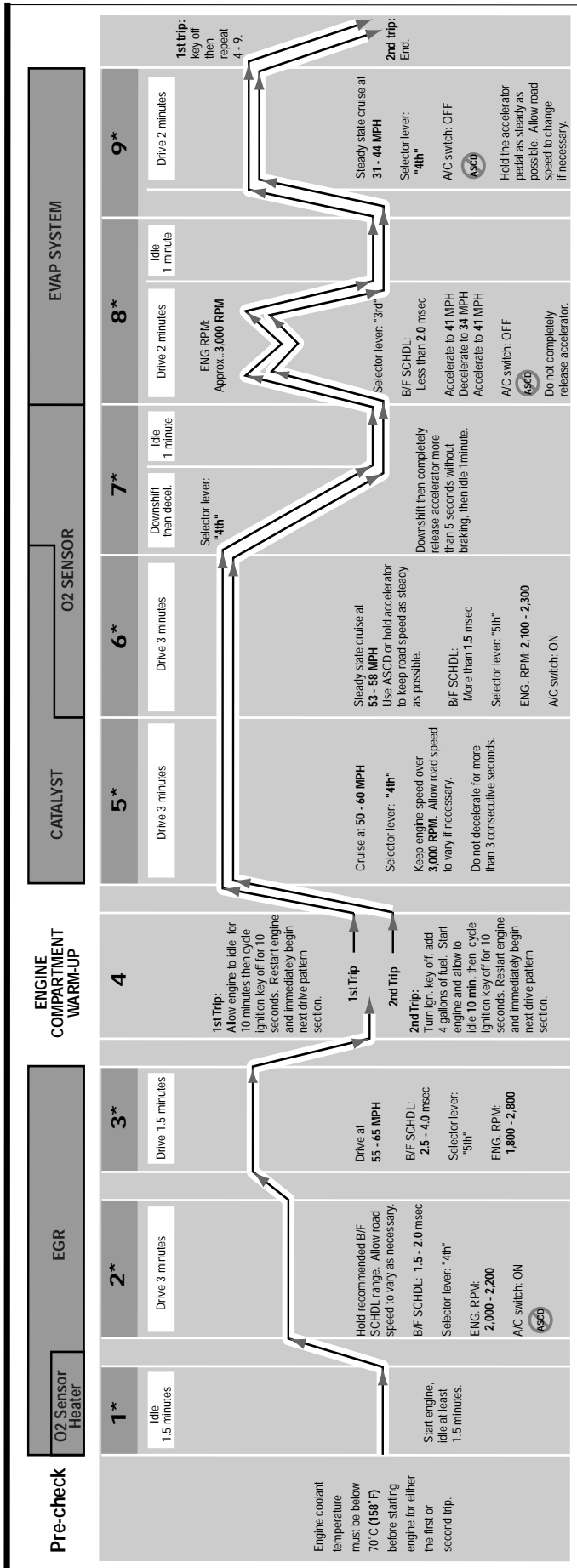

NOTE: It is better to perform this driving test when fuel level is less than 1/2.

If fuel level is greater than 1/2 more time may be required to complete EVAP sections of the drive pattern. Also you may be unable to add fuel as required.

* Dark shading behind section number indicates this drive pattern section must be repeated, without turning the ignition off, if it is interrupted by releasing the accelerator when not directed to do so.

System Readiness Test Drive Pattern #38

ECM Part Numbers: 23710-72F10, -72F11, -72F12, -72F13, -72F14, -72F15

Two Trip Logic

First Trip: Drive all sections 1 through 9.

Second Trip: Turn ign. off. Add 4 gallons fuel. Start engine and drive sections 4, 5, 6, 7, 8, 9.

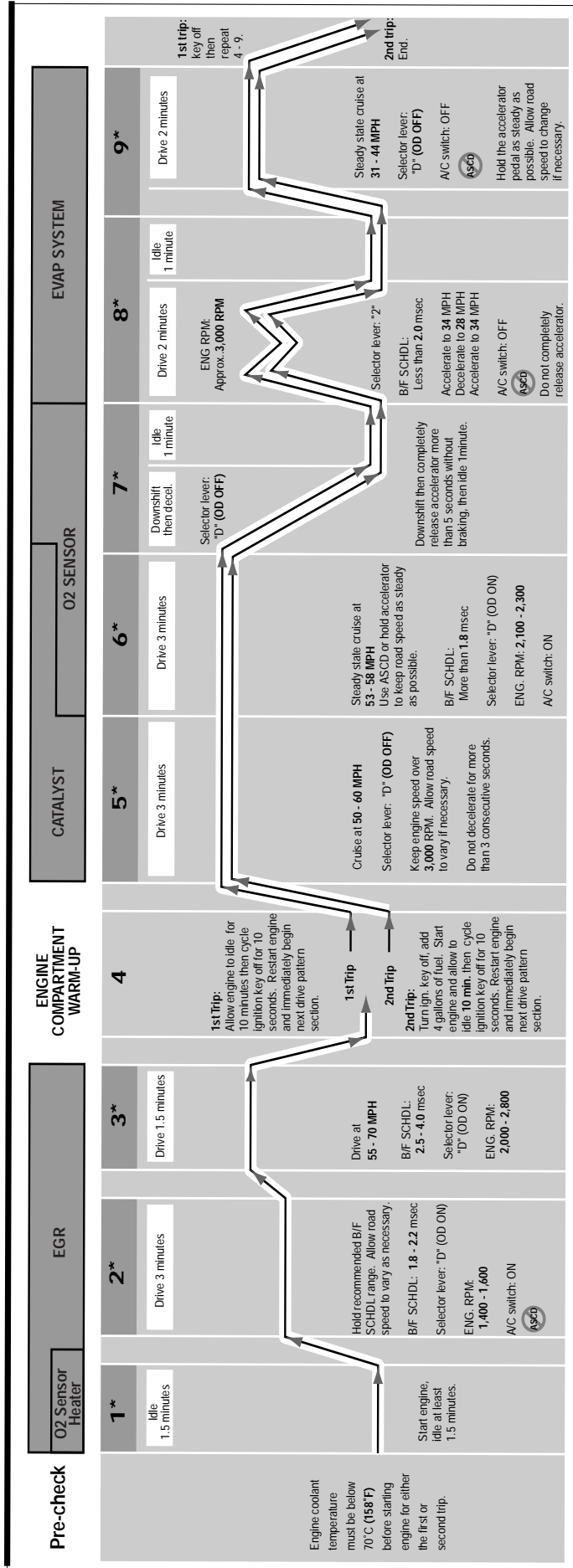

NOTE: It is better to perform this driving test when fuel level is less than 1/2.

If fuel level is greater than 1/2 more time may be required to complete EVAP sections of the drive pattern. Also you may be unable to add fuel as required.

* Dark shading behind section number indicates this drive pattern section must be repeated, without turning the ignition off, if it is interrupted by releasing the accelerator when not directed to do so.

System Readiness Test Drive Pattern #39

ECM Part Numbers: 23710-81F00, -81F01, -81F02, -81F03

All Items: Two Trip Logic. Drive all sections two times.

First Trip: Drive all sections 1 through 8 then turn ign. off and allow engine to cool below 70°C. (158°F).

Second Trip: Start engine, drive sections 1,2,3. Turn ign. off and add 4 gallons of fuel in section 4, then start engine and drive sections 5, 6, 7, 8.

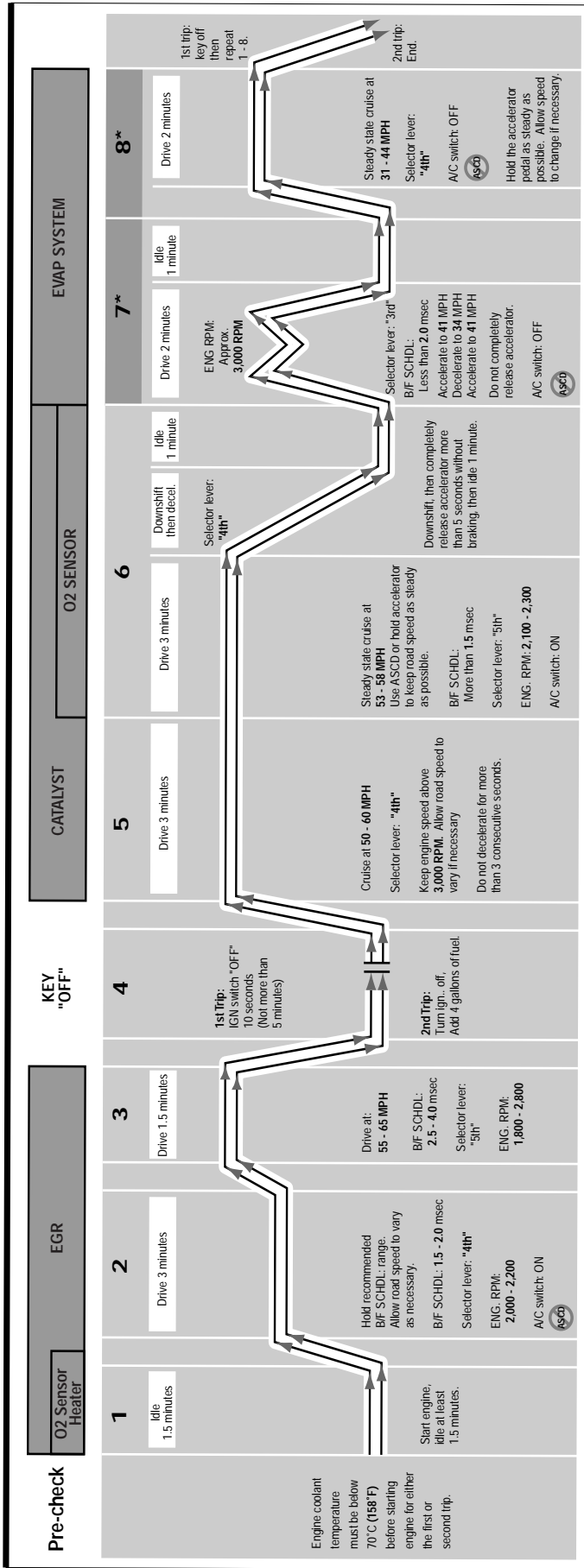

NOTE: It is better to perform this driving test when fuel level is less than 1/2. If fuel level is greater than 1/2 more time may be required to complete EVAP sections of the drive pattern. Also you may be unable to add fuel as required.

* Dark shading behind section number indicates this drive pattern section must be repeated, without turning the ignition off, if it is interrupted by releasing the accelerator when not directed to do so.

'97 240SX M/T

System Readiness Test Drive Pattern #40

ECM Part Numbers: 23710-81F10, -81F11, -81F12, -81F13

All Items: Two Trip Logic. Drive all sections two times.

First Trip: Drive all sections 1 through 8 then turn ign. off and allow engine to cool below 70°C. (158°F).

Second Trip: Start engine, drive sections 1,2,3. Turn ign. off and add 4 gallons of fuel in section 4, then start engine and drive sections 5, 6, 7, 8.

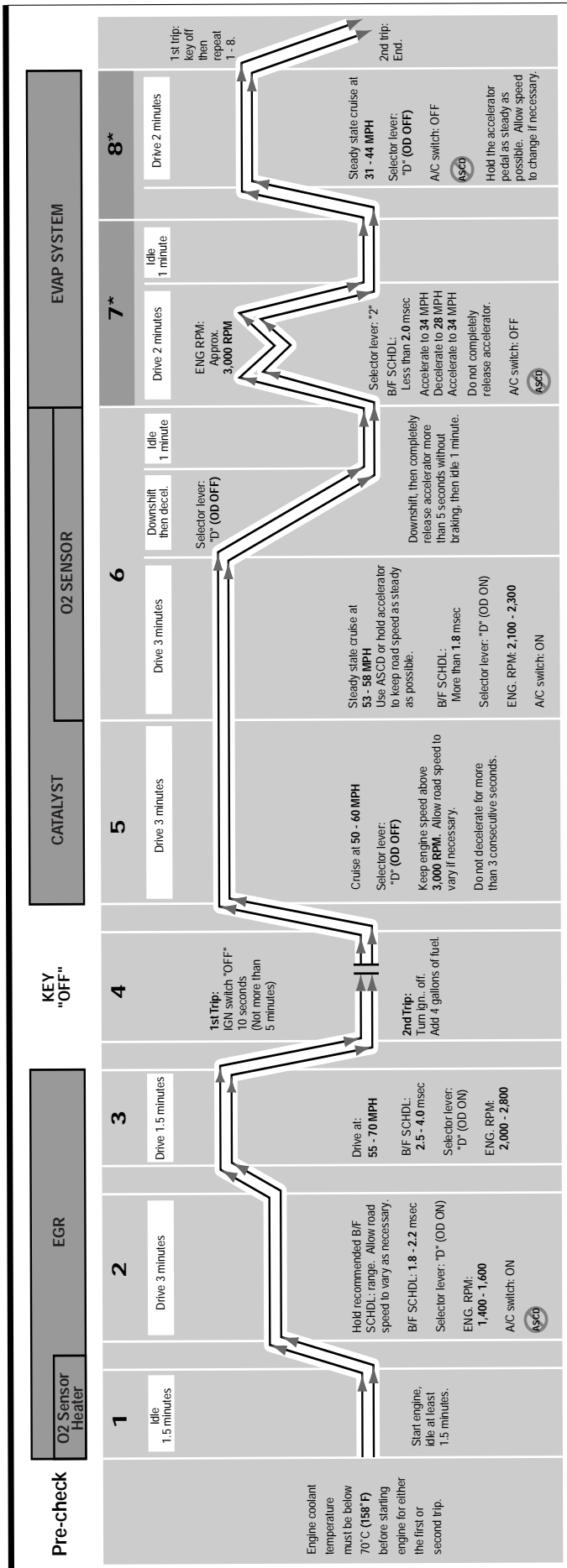

'97 240SX A/T

System Readiness Test Drive Pattern #41

ECM Part Numbers: 23710-54P60, -54P61

One Trip Logic for all sections.
Drive all sections one time.

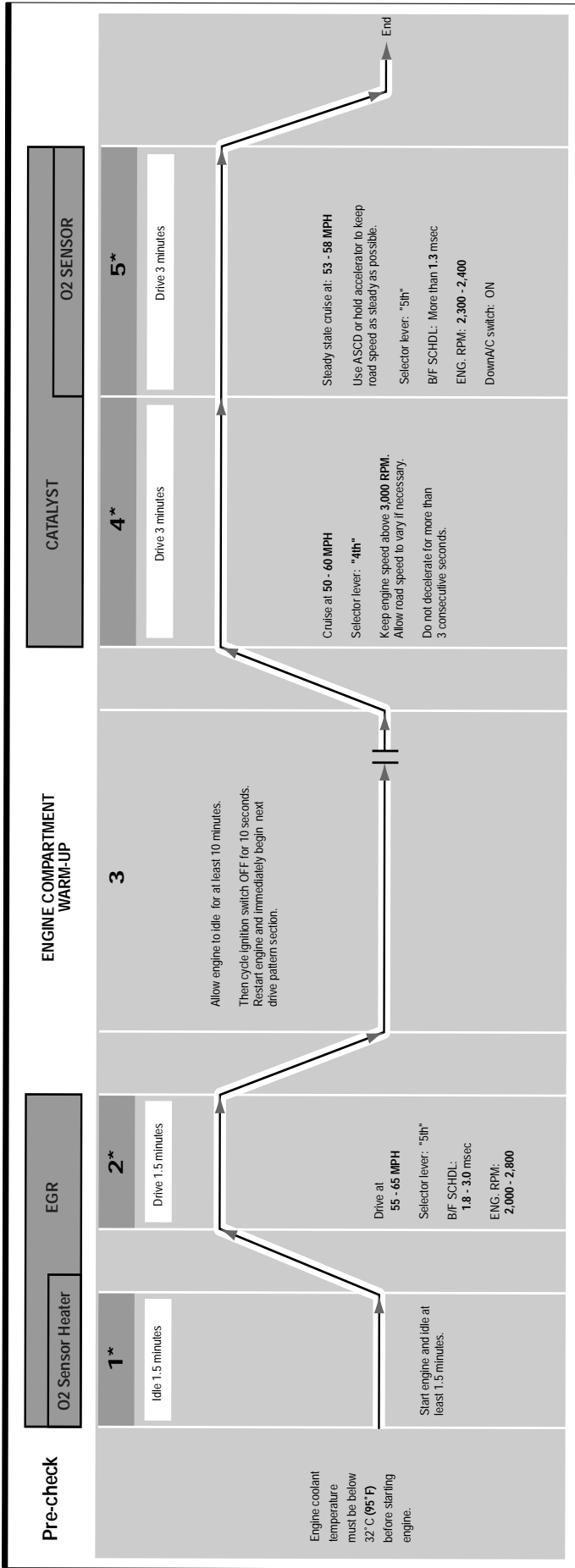

* Dark shading behind section number indicates this drive pattern section must be repeated, without turning the ignition off, if it is interrupted by releasing the accelerator when not directed to do so.

'96 300ZX (Non-turbo) M/T

System Readiness Test Drive Pattern #42

ECM Part Numbers: 23710-54P62, -54P74

All Items: Two Trip Logic.

First Trip: Drive all sections 1 through 5, then turn ign. off and allow engine to cool to 158°F. to meet Pre-check condition for second trip.

Second Trip: Drive all sections 1 through 5 again.

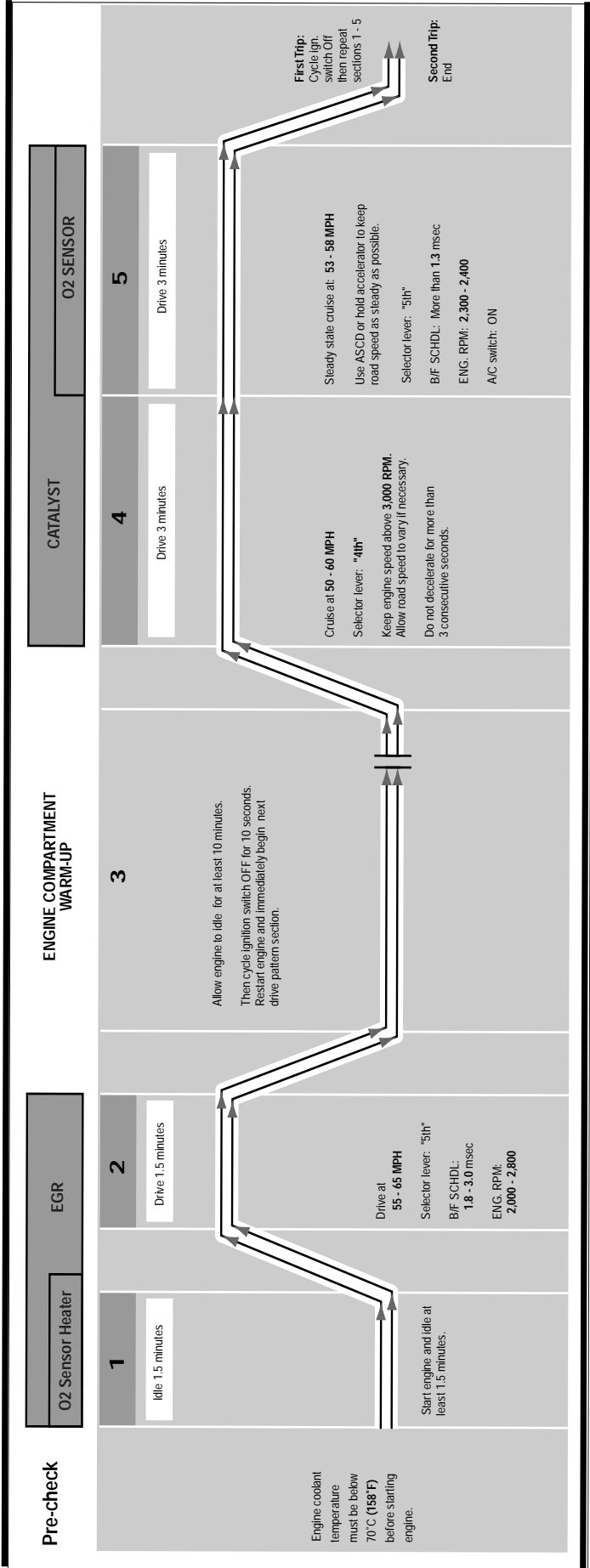

* Dark shading behind section number indicates this drive pattern section must be repeated, without turning the ignition off, if it is interrupted by releasing the accelerator when not directed to do so.

'96 300ZX (Non-turbo) M/T

System Readiness Test Drive Pattern #43

ECM Part Numbers: 23710-54P65, -54P66

One Trip Logic for all sections.
Drive all sections one time.

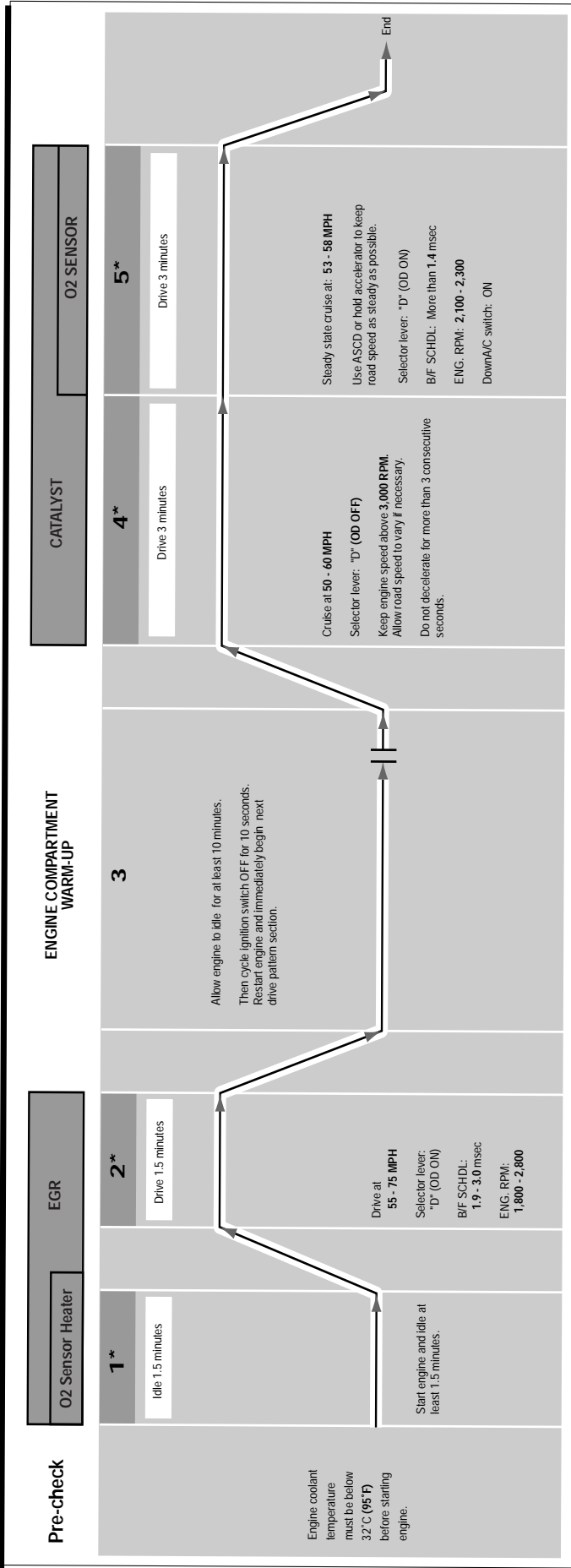

* Dark shading behind section number indicates this drive pattern section must be repeated, without turning the ignition off, if it is interrupted by releasing the accelerator when not directed to do so.

'96 300ZX (Non-turbo) A/T

System Readiness Test Drive Pattern #44

ECM Part Numbers: 23710-54P67, -54P75

All Items: Two Trip Logic.

First Trip: Drive all sections 1 through 5, then turn ign. off and allow engine to cool to 158°F. to meet Pre-check condition for second trip.

Second Trip: Drive all sections 1 through 5 again.

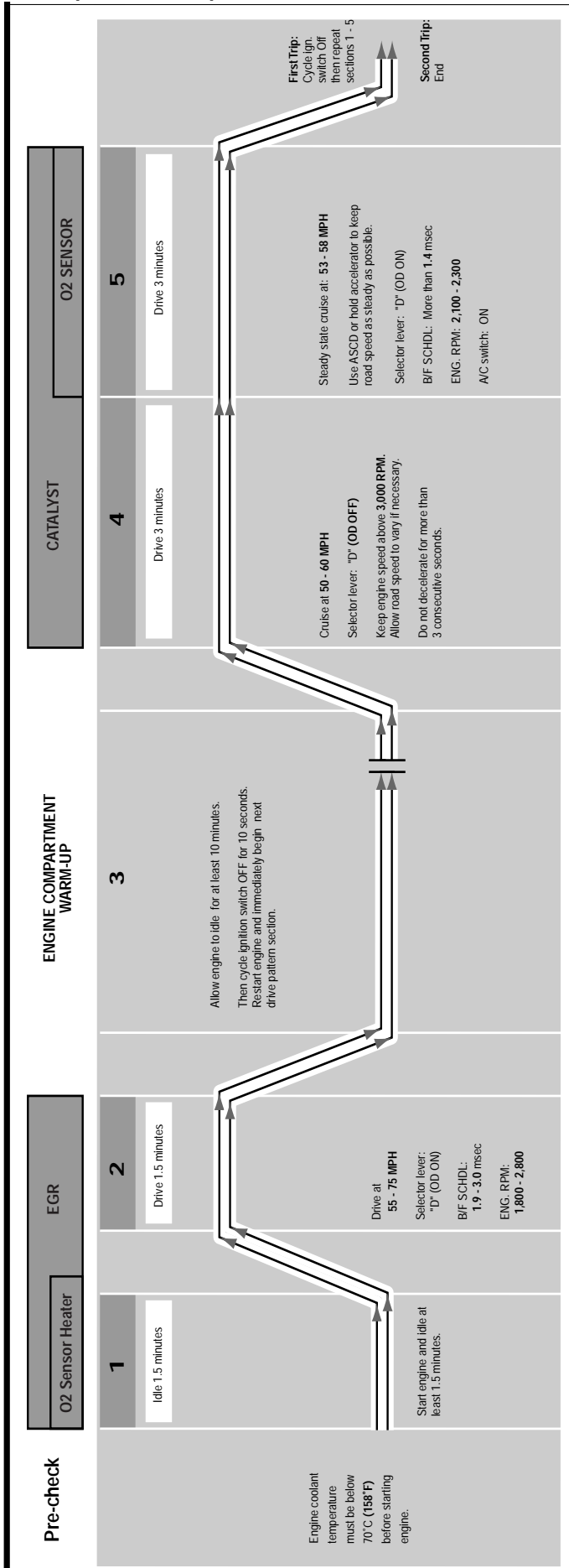

* Dark shading behind section number indicates this drive pattern section must be repeated, without turning the ignition off, if it is interrupted by releasing the accelerator when not directed to do so.

'96 300ZX (Non-turbo) A/T

System Readiness Test Drive Pattern #45

ECM Part Numbers: 23710-54P00, -54P01, -54P02, -54P03, -54P04, -54P70

One Trip Logic for all sections.
Drive all sections one time.

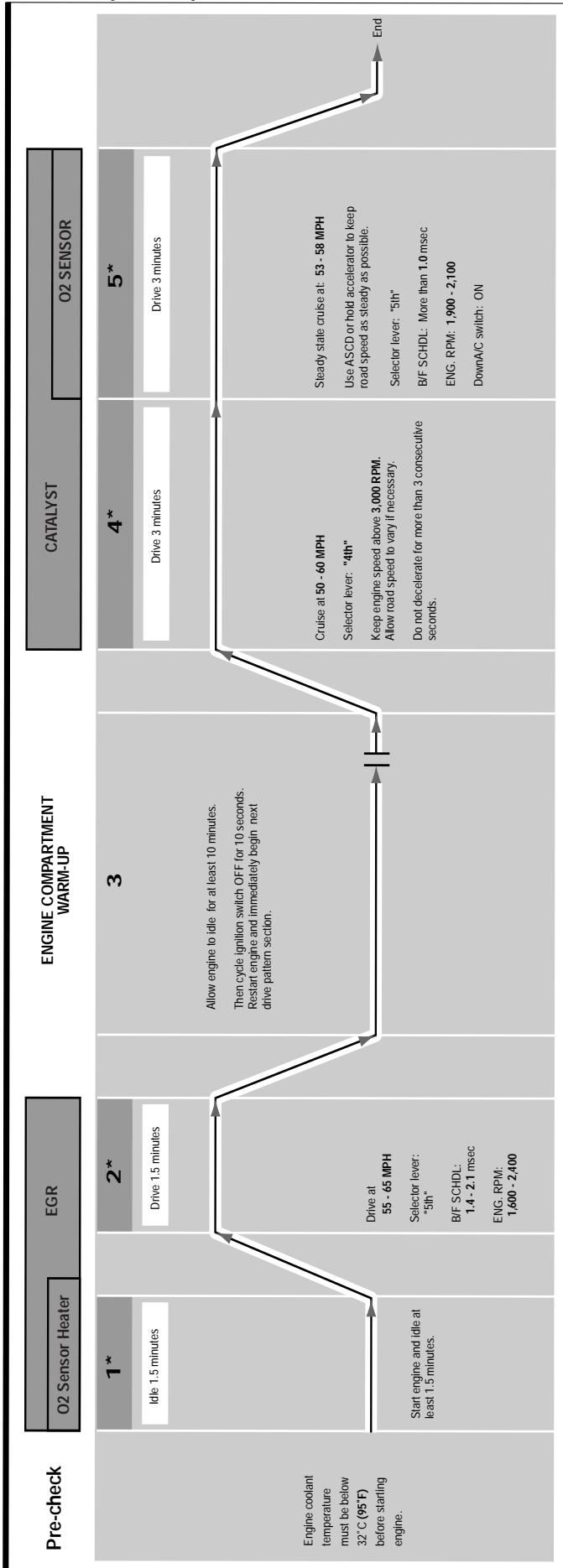

System Readiness Test Drive Pattern #46

ECM Part Numbers: 23710-54P05, -54P06, -54P07, -54P08, -54P09, -54P71

One Trip Logic for all sections.
Drive all sections one time.

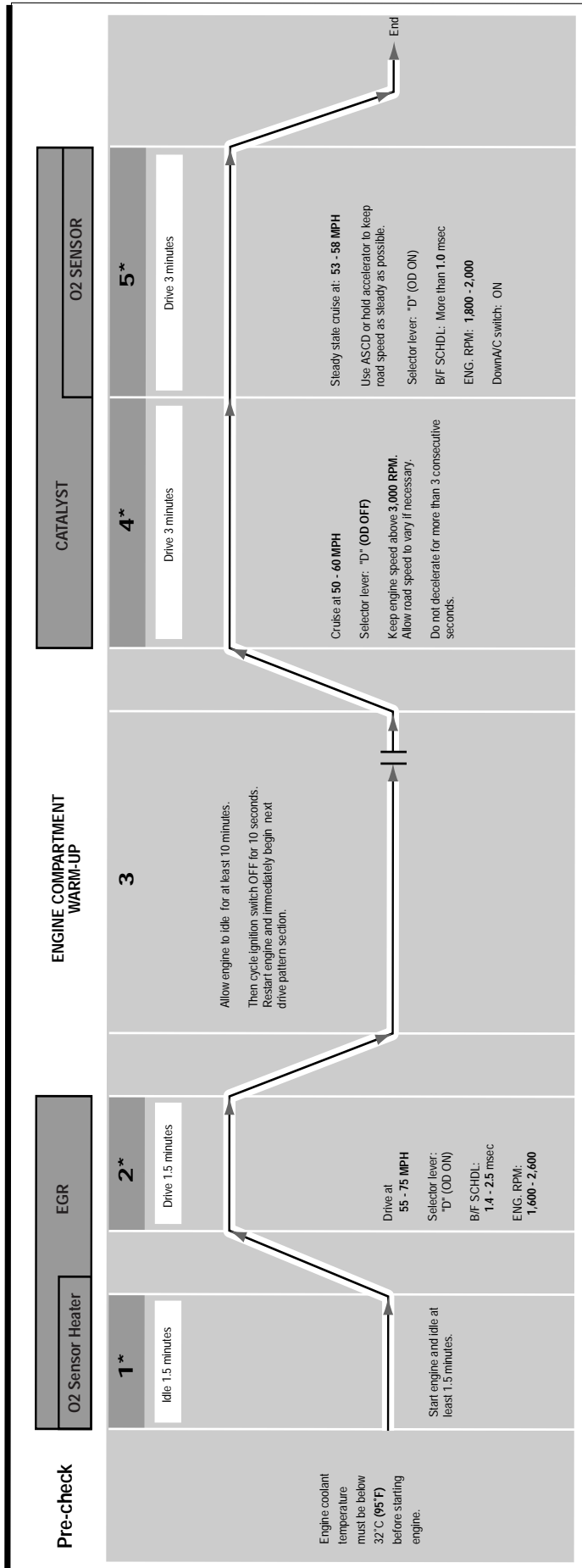

* Dark shading behind section number indicates this drive pattern section must be repeated, without turning the ignition off, if it is interrupted by releasing the accelerator when not directed to do so.